



18

Gynäkologie und Geburtshilfe

Gynecology and obstetrics

Gynécologie et obstétrique

Ginecología y obstetricia

Ginegologia e ostetricia



Scheidenspekula
Vaginal specula

Spéculums vaginaux
Espéculos vaginales
Specoli vaginali



Scheidenspekula mit Absaugung auf Anfrage lieferbar.
Specula with aspiration are available upon request.
Spéculums avec aspiration sont disponibles sur demande.
Espéculos con aspiración son disponibles según demanda.
A richiesta gli specoli sono fornibili anche con tubo d'aspirazione.



CUSCO

75 mm x 32 mm	61-031-001
85 mm x 35 mm	61-031-002
100 mm x 35 mm	61-031-003



CUSCO

75 mm x 32 mm	61-041-001
85 mm x 35 mm	61-041-002
100 mm x 37 mm	61-041-003

175 mm x 17 mm	61-021-000
----------------	------------

für Jungfrauen
for virgins
pour vierges
para vírgenes
per vergine

Scheidenspekula
Vaginal specula
Spéculums vaginaux
Espéculos vaginales
Specoli vaginali

Scheidenspekula mit Absaugung auf Anfrage lieferbar.

Specula with aspiration are available upon request.

Spéculums avec aspiration sont disponibles sur demande.

Espéculos con aspiración son disponibles según demanda.

A richiesta gli specoli sono fornibili anche con tubo d'aspirazione.

CUSCO

90 mm x 23 mm	61-043-001
100 mm x 25 mm	61-043-002
105 mm x 27 mm	61-043-003

Schweizer Modell

Swiss pattern

Modèle suisse

Modelo suizo

Modello svizzero

GRAVE

75 mm x 20 mm	61-061-001
95 mm x 35 mm	61-061-002
115 mm x 35 mm	61-061-003

Scheidenspekula
Vaginal specula

Spéculums vaginaux
Espéculos vaginales
Specoli vaginali



Scheidenspekula mit Absaugung auf Anfrage lieferbar.
Specula with aspiration are available upon request.
Spéculums avec aspiration sont disponibles sur demande.
Espéculos con aspiración son disponibles según demanda.
A richiesta gli specoli sono fornibili anche con tubo d'aspirazione.



SEMM

90 mm x 14/18 mm	61-081-000
100 mm x 17/20 mm	61-081-001
100 mm x 25/30 mm	61-081-002



COLLIN

90 mm x 16 mm	61-051-000
90 mm x 28 mm	61-051-001
100 mm x 35 mm	61-051-002
110 mm x 40 mm	61-051-003



TRELAT

85 mm x 33 mm	369-176-010
95 mm x 35 mm	369-176-020
115 mm x 43 mm	369-176-030



PEDERSON

75 mm x 13 mm	369-116-010
100 mm x 22 mm	369-116-020
120 mm x 25 mm	369-116-030

Scheidenspekula
Vaginal specula
Spéculums vaginaux
Espéculos vaginales
Specoli vaginali

KRISTELLER

70 mm x 27 mm	61-151-001
80 mm x 30 mm	61-151-002
90 mm x 36 mm	61-151-003
110 mm x 27 mm	369-237-010
110 mm x 30 mm	369-237-020
110 mm x 36 mm	369-237-030

Spekulum
 Speculum
 Spéculum
 Espéculo
 Specolo

75 mm x 23 mm	61-153-001
85 mm x 26 mm	61-153-002
100 mm x 32 mm	61-153-003
115 mm x 23 mm	369-238-010
115 mm x 26 mm	369-238-020
115 mm x 32 mm	369-238-030

Halter
 Retractor
 Valve
 Valva
 Valve

61-155-001
61-155-002
61-155-003
369-236-010
369-236-020
369-236-030

Satz
 Set
 Jeu
 Juego
 Serie

Scheidenspekula
Vaginal specula

Spéculums vaginaux
Espéculos vaginales
Specoli vaginali



KRISTELLER

105 mm x 18 mm	369-217-010
105 mm x 21 mm	369-217-020

Spekulum konisch, für Jungfrauen
 Speculum tapered, for virgins
 Spéculum conique, pour vierges
 Espéculo cónico, para vírgenes
 Specolo conico, per virgini

110 mm x 14 mm	369-218-010
115 mm x 17 mm	369-218-020

Halter
 Retractor
 Valve
 Valva
 Valva

369-216-010
369-216-020

Satz
 Set
 Jeu
 Juego
 Serie

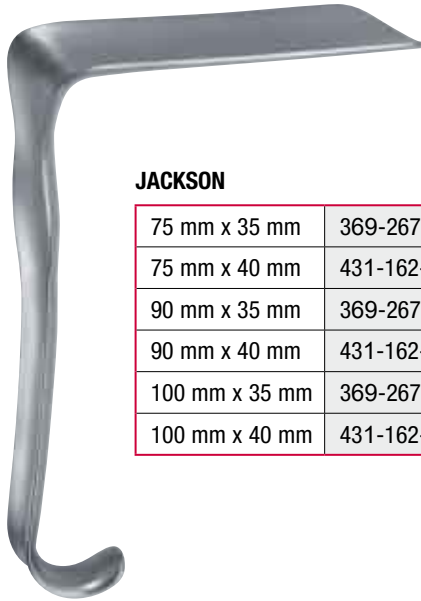
Scheidenspekula
Vaginal specula
Spéculums vaginaux
Espéculos vaginales
Specoli vaginali

JACKSON

75 mm x 35 mm	369-267-010
75 mm x 40 mm	431-162-010
90 mm x 35 mm	369-267-020
90 mm x 40 mm	431-162-020
100 mm x 35 mm	369-267-030
100 mm x 40 mm	431-162-030

AUVARD

220 mm – 8 ¾"
80 mm x 38 mm
61-221-220



60 mm x 25 mm/30 mm	70 mm x 30 mm/35 mm	80 mm x 35 mm/40 mm
61-131-001	61-131-002	61-131-003

SIMS

62-131-000	x	x	x
------------	---	---	---

Satz
 Set
 Jeu
 Juego
 Serie

Scheidenspekula
Vaginal specula

Spéculums vaginaux
Espéculos vaginales
Specoli vaginali



KALLMORGEN

70 mm x 40 mm	369-257-010
90 mm x 40 mm	369-257-020

Spekulum
 Speculum
 Spéculum
 Espéculo
 Specolo

70 mm x 33 mm	369-258-010
90 mm x 33 mm	369-258-020

Halter
 Retractor
 Valve
 Valva
 Valve

369-256-010
369-256-020

Satz
 Set
 Jeu
 Juego
 Serie

Scheidenspekula

Vaginal specula

Spéculums vaginaux

Espéculos vaginales

Specoli vaginali



LANDAU

	290 mm – 11 ½"
100 mm x 28 mm	369-315-280
100 mm x 38 mm	369-315-380

Scheidenspekula
Vaginal specula

Spéculums vaginaux
Espéculos vaginales
Specoli vaginali



BREISKY

	300 mm – 12"
130 mm x 10 mm	61-163-010
130 mm x 15 mm	61-163-015
130 mm x 20 mm	61-163-020
130 mm x 25 mm	61-163-025
130 mm x 30 mm	61-163-030
130 mm x 35 mm	61-163-035
130 mm x 40 mm	61-163-040

Wiener Modell
Vienna pattern
Modèle Vienne
Modelo Vienna
Modello Vienna

	300 mm – 12"
100 mm x 10 mm	61-161-010
100 mm x 15 mm	61-161-015
100 mm x 20 mm	61-161-020
100 mm x 25 mm	61-161-025
100 mm x 30 mm	61-161-030
100 mm x 35 mm	61-161-035
100 mm x 40 mm	61-161-040
115 mm x 10 mm	61-162-010
115 mm x 15 mm	61-162-015
115 mm x 20 mm	61-162-020
115 mm x 25 mm	61-162-025
115 mm x 30 mm	61-162-030
115 mm x 35 mm	61-162-035
115 mm x 40 mm	61-162-040

	350 mm – 13 3/4"
160 mm x 20 mm	61-165-020
160 mm x 25 mm	61-165-025
160 mm x 30 mm	61-165-030
160 mm x 35 mm	61-165-035
160 mm x 40 mm	61-165-040
180 mm x 20 mm	61-167-020
180 mm x 25 mm	61-167-025
180 mm x 30 mm	61-167-030
180 mm x 35 mm	61-167-035
180 mm x 40 mm	61-167-040

Scheidenspekula
Vaginal specula
Spéculums vaginaux
Espéculos vaginales
Specoli vaginali

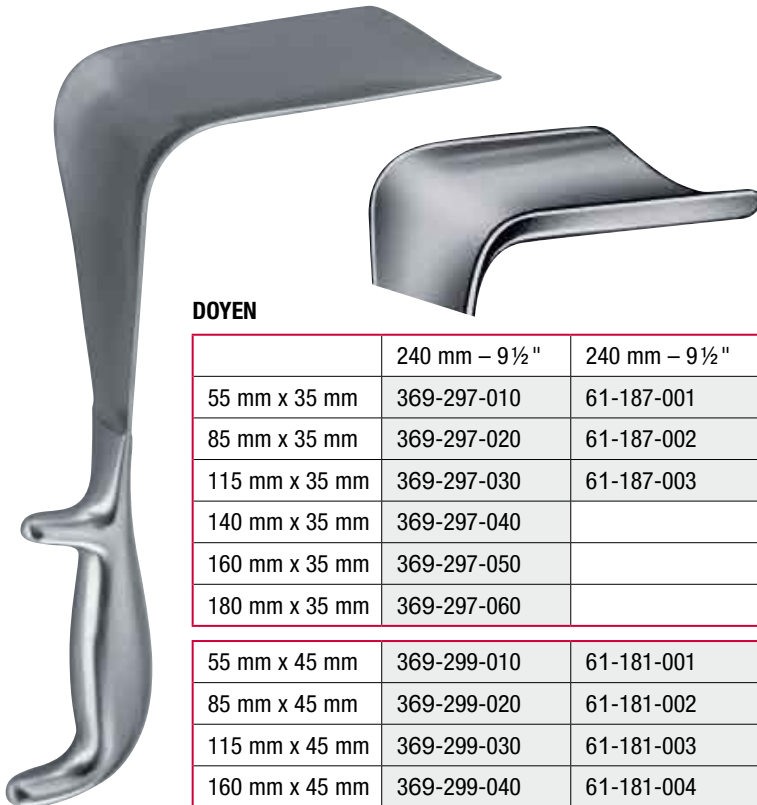

Fig. 1	Fig. 2	Fig. 3	Fig. 4	Fig. 5
80 mm x 30 mm	85 mm x 35 mm	90 mm x 40 mm	55 mm x 40 mm / 60 mm	70 mm x 45 mm / 70 mm
61-231-001	61-231-002	61-231-003	61-231-004	61-231-005

SCHERBACK
61-231-000

Satz mit 400 g Gewicht 431-298-100
 Set with weight 400 grs. 431-298-100
 Jeu avec poid 400 gr. 431-298-100
 Juego con peso 400 gr. 431-298-100
 Serie con peso di 400 gr. 431-298-100



400 g	61-237-400
600 g	61-237-600
800 g	61-237-800

61-235-000

DOYEN

	240 mm – 9 ½"	240 mm – 9 ½"
55 mm x 35 mm	369-297-010	61-187-001
85 mm x 35 mm	369-297-020	61-187-002
115 mm x 35 mm	369-297-030	61-187-003
140 mm x 35 mm	369-297-040	
160 mm x 35 mm	369-297-050	
180 mm x 35 mm	369-297-060	
55 mm x 45 mm	369-299-010	61-181-001
85 mm x 45 mm	369-299-020	61-181-002
115 mm x 45 mm	369-299-030	61-181-003
160 mm x 45 mm	369-299-040	61-181-004
180 mm x 45 mm	369-299-050	

55 mm x 60 mm	369-301-010	61-191-001
85 mm x 60 mm	369-301-020	61-191-002
115 mm x 60 mm	369-301-030	61-191-003
160 mm x 60 mm	369-301-040	
180 mm x 60 mm	369-301-050	

leichthohl
 slightly concave
 légèrement concave
 ligeramente concava
 legermente concavo

halbhohl
 medium concave
 semi concave
 semi concava
 semi concavo

Endospekula

Endospecula

Endospéculums

Endospéculos

Endospecoli

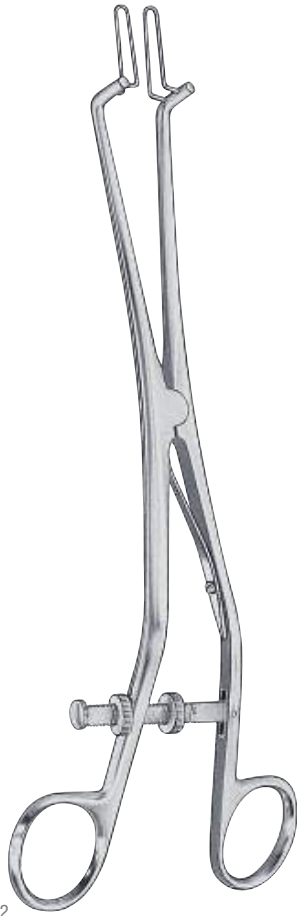

1:2

KOGAN

240 mm – 9½"

369-356-240

mit Skalensperre und Stellschraube
 with scale-ratchet and fixation screw
 avec crémaillère à échelle et vis à fixation
 con cremallera graduada y tornillo fijación
 con cremagliera graduata e vite di fissaggio



1:2

KOGAN

240 mm – 9½"

431-377-240



1:2

KOGAN-MODIF.

280 mm – 11"

x = 2 mm y = 4 mm

369-362-240

x = 4 mm y = 8 mm

369-362-480

Parametriumklemmen

Parametrium forceps

Pinces parametrium

Pinzas parametrium

Pinze parametrium

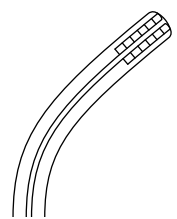
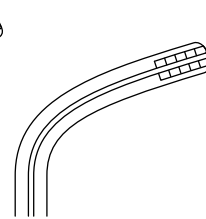
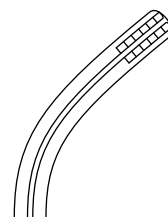
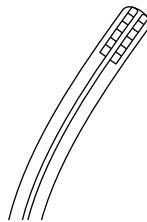

210 mm – 8¼"	12-913-210	12-915-210	12-917-210	12-919-210	12-921-210
240 mm – 9½"	12-913-240	12-915-240	12-917-240	12-919-240	12-921-240
260 mm – 10¼"	12-913-260	12-915-260	12-917-260	12-919-260	12-921-260
300 mm – 12"	12-913-300	12-915-300	12-917-300	12-919-300	12-921-300
350 mm – 13¾"	12-913-350	12-915-350	12-917-350	12-919-350	12-921-350

S-förmig gebogen

S-curved

coube en S

curva en S

curva a forma di S

Hysterektomieklemmen
Hysterectomy forceps

Pinces à hystérectomie
Pinzas-clamps para hysterectomía
Pinze per isterectomia

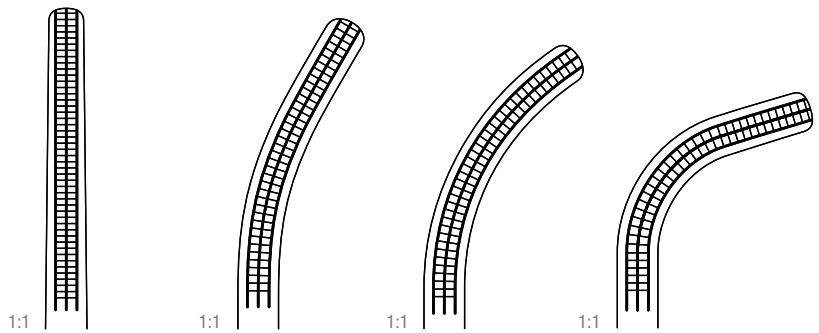

ROGERS

Atrauma	Atrauma	Atrauma	Atrauma
Fig. 1	Fig. 2	Fig. 3	Fig. 4
220 mm – 8¾"	215 mm – 8½"	210 mm – 8¼"	205 mm – 8"
412-631-100	412-631-200	412-631-300	412-631-400

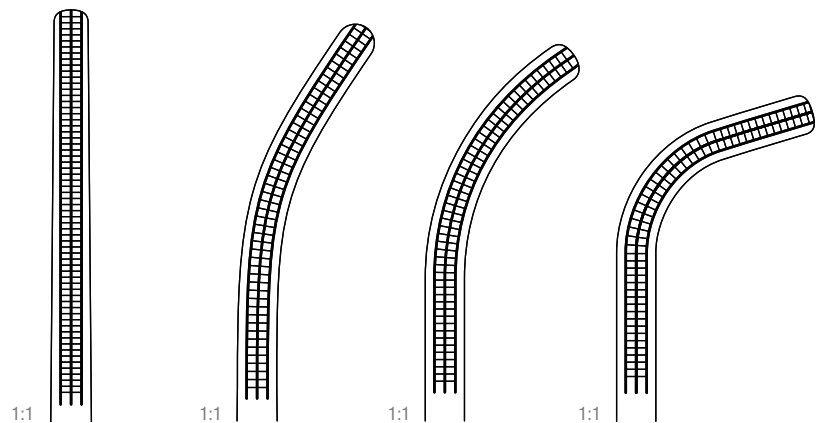

Atrauma	Atrauma	Atrauma	Atrauma
Fig. 1	Fig. 2	Fig. 3	Fig. 4
250 mm – 9¾"	250 mm – 9¾"	245 mm – 9¾"	230 mm – 9"
412-633-100	412-633-200	412-633-300	412-633-400

Uterus-Sonden
Uterine sounds
Hystéromètres du col de l'utérus
Histerómetros uterinos
Isterometri uterini

1:2

VALLEIX

250 mm – 9¾"

 431-589-
250

 graduiert, mit Schieber
 graduated, with slider
 gradué, avec curseur
 graduado, con cursor
 graduato, con cursore

1:2

MARTIN

320 mm – 12½"

61-507-320

61-509-320

fest
 rigid
 rigide
 rígido
 rigido

biegsam
 malleable
 malléable
 maleable
 malleabile

1:2

SIMS

320 mm – 12½"

61-501-320

61-503-320

fest
 rigid
 rigide
 rígido
 rigido

biegsam
 malleable
 malléable
 maleable
 malleabile

Uterus-Dilatatoren

Uterine dilators

Dilatateurs du col de l'utérus

Dilatadores uterinos

Dilatatori uterini

HEGAR



1.0 mm Ø	61-351-001
1.5 mm Ø	61-353-015
2.0 mm Ø	61-351-002
2.5 mm Ø	61-353-025
3.0 mm Ø	61-351-003
3.5 mm Ø	61-353-035
4.0 mm Ø	61-351-004
4.5 mm Ø	61-353-045
5.0 mm Ø	61-351-005
5.5 mm Ø	61-353-055
6.0 mm Ø	61-351-006
6.5 mm Ø	61-353-065
7.0 mm Ø	61-351-007
7.5 mm Ø	61-353-075
8.0 mm Ø	61-351-008
8.5 mm Ø	61-353-085
9.0 mm Ø	61-351-009
9.5 mm Ø	61-353-095

10.0 mm Ø	61-351-010
10.5 mm Ø	61-353-105
11.0 mm Ø	61-351-011
11.5 mm Ø	61-353-115
12.0 mm Ø	61-351-012
12.5 mm Ø	61-353-125
13.0 mm Ø	61-351-013
13.5 mm Ø	61-353-135
14.0 mm Ø	61-351-014
14.5 mm Ø	61-353-145
15.0 mm Ø	61-351-015
15.5 mm Ø	61-353-155
16.0 mm Ø	61-351-016
16.5 mm Ø	61-353-165
17.0 mm Ø	61-351-017
17.5 mm Ø	61-353-175
18.0 mm Ø	61-351-018
18.5 mm Ø	61-353-185
19.0 mm Ø	61-351-019
19.5 mm Ø	61-353-195

20.0 mm Ø	61-351-020
21.0 mm Ø	61-351-021
22.0 mm Ø	61-351-022
23.0 mm Ø	61-351-023
24.0 mm Ø	61-351-024
25.0 mm Ø	61-351-025
26.0 mm Ø	61-351-026
27.0 mm Ø	61-351-027
28.0 mm Ø	61-351-028
29.0 mm Ø	61-351-029
30.0 mm Ø	61-351-030

HEGAR

3 mm – 10 mm Ø	8	61-351-500
4 mm – 17 mm Ø	14	61-351-501
1 mm – 26 mm Ø	26	61-351-000
3 mm – 13 mm Ø	10	61-333-313

Stück per Satz
 Pieces per set
 Pièces per jeu
 Piezas para juego
 Pezzi per serie

Satz, ohne Metalletui
 Set, without metal case
 Jeu, sans boîte en métal
 Juego, sin caja de metal
 Serie, senza astuccio metallico

Uterus-Dilatatoren

Uterine dilators

Dilatateurs du col de l'utérus

Dilatadores uterinos

Dilatatori uterini



1:3



1:3

4 mm – 17 mm Ø	14	61-358-000
1 mm – 26 mm Ø	26	61-360-000

Stück per Satz
Pieces per set
Pièces per jeu
Piezas para juego
Pezzi per serie

Satz, in Metalletui
Set, in metal case
Jeu, en boîte en métal
Juego, en caja de metal
Serie, con astuccio metallico

Uterus-Dilatatoren
Uterine dilators

Dilatateurs du col de l'utérus
Dilatadores uterinos
Dilatatori uterini



HEGAR

1/2 mm Ø	61-371-001
3/4 mm Ø	61-371-003
5/6 mm Ø	61-371-005
7/8 mm Ø	61-371-007
9/10 mm Ø	61-371-009
11/12 mm Ø	61-371-011
13/14 mm Ø	61-371-013
15/16 mm Ø	61-371-015
17/18 mm Ø	61-371-017
19/20 mm Ø	61-371-019
21/22 mm Ø	61-371-021
23/24 mm Ø	61-371-023
25/26 mm Ø	61-371-025

HEGAR

3/4 mm – 17/18 mm Ø	8	369-420-080
1/2 mm – 25/26 mm Ø	13	369-420-130

Stück per Satz
 Pieces per set
 Pièces per jeu
 Piezas para juego
 Pezzi per serie

Satz, ohne Metalletui
 Set, without metal case
 Jeu, sans boîte en métal
 Juego, sin caja de metal
 Serie, senza astuccio metallico



1:3



1:3

HEGAR

3/4 mm – 17/18 mm Ø	8	61-374-002	61-374-000
1/2 mm – 25/26 mm Ø	13		61-378-000

Stück per Satz
 Pieces per set
 Pièces per jeu
 Piezas para juego
 Pezzi per serie

Satz in Stoffrolltasche
 Set in canvas roll
 Jeu en poche de textile
 Juego en bolsa de tela
 Serie in astuccio di tela

Satz, in Metalletui
 Set, in metal case
 Jeu, en boîte en métal
 Juego, en caja de metal
 Serie, con astuccio metallico

Uterus-Dilatatoren
Uterine dilators
Dilatateurs du col de l'utérus
Dilatadores uterinos
Dilatatori uterini

HANK

Fig. 9/10	4.5/5.0 mm Ø	369-426-100
Fig. 11/12	5.5/6.0 mm Ø	369-426-120
Fig. 13/14	6.5/7.0 mm Ø	369-426-140
Fig. 15/16	7.5/8.0 mm Ø	369-426-160
Fig. 17/18	8.5/9.0 mm Ø	369-426-180
Fig. 19/20	9.5/10.0 mm Ø	369-426-200

HANK

4.5/5 mm – 9.5/10 mm Ø	6	369-431-060
------------------------	---	-------------

Stück per Satz
 Pieces per set
 Pièces per jeu
 Piezas para juego
 Pezzi per serie

Satz, allein
 Set, only
 Jeu, seul
 Juego, sólo
 Serie, solo

BRAUN 1:3

280 mm – 11 "

61-527-280

1:3

HANK

4.5/5 mm – 9.5/10 mm Ø	6	369-432-080
------------------------	---	-------------

Stück per Satz
 Pieces per set
 Pièces per jeu
 Piezas para juego
 Pezzi per serie

Satz in Stoffrolle
 Set in canvas roll
 Jeu en poche de textile
 Juego en bolsa de tela
 Serie in astuccio di tela



Hakenzangen

Tenaculum forceps

Pinces pour l'abaissement du col de l'utérus

Pinzas para coger el cuello del utero

Pinze per abbassare il collo dell'utero



1:2

**STAUDE-
MOORE**

170 mm – 6 ¾"

369-504-170



1:2

BARRETT

180 mm – 7"

369-506-180



1:2

SKENE

240 mm – 9 ½"

369-501-240



1:2

BRAUN

250 mm – 9 ¾"

369-500-250

Hakenzangen

Tenaculum forceps

Pinces pour l'abaissement du col de l'utérus

Pinzas para coger el cuello del utero

Pinze per abbassare il collo dell'utero



POZZI

255 mm – 10"

369-502-250



SCHROEDER

250 mm – 9¾"

16-520-250



SCHROEDER

240 mm – 9½"



1:2

16-560-240



1:2

16-561-240

Hakenzangen

Tenaculum forceps

Pinces pour l'abaissement du col de l'utérus

Pinzas para coger el cuello del utero

Pinze per abbassare il collo dell'utero



DUPLAY 1:2

280 mm – 11"

16-541-280



IOWA 1:2

260 mm – 10 ¼"

369-535-260



BEACHAM 1:2

260 mm – 10 ¼"

369-555-260

Amniotom
Amniotome
Amniotomo
Amniótomo
Amniotomo

Hakenzangen
Tenaculum forceps
Pinces pour l'abaissement du col de l'utérus
Pinzas para coger el cuello del utero
Pinze per abbassare il collo dell'utero

MUSEUX

	240 mm – 9½"	240 mm – 9½"
6 mm	16-590-006	16-591-006
8 mm	16-590-008	16-591-008
10 mm	16-590-010	16-591-010



1:2

JACOBS

210 mm – 8¼"	16-588-215	16-589-215
--------------	------------	------------



1:2

TEALE

230 mm – 9"	16-577-230
-------------	------------

Hakenzangen

Tenaculum forceps

Pinces pour l'abaissement du col de l'utérus

Pinzas para coger el cuello del útero

Pinze per abbassare il collo dell'utero



1:2

PRATT

280 mm – 11 "

369-532-280



1:2

CZERNY

205 mm – 8 "

431-736-210

Uterus-Polypenzangen

Uterine polypus forceps

Pinces à polypes utérins

Pinzas para pólipos uterinos

Pinze per polipi uterini

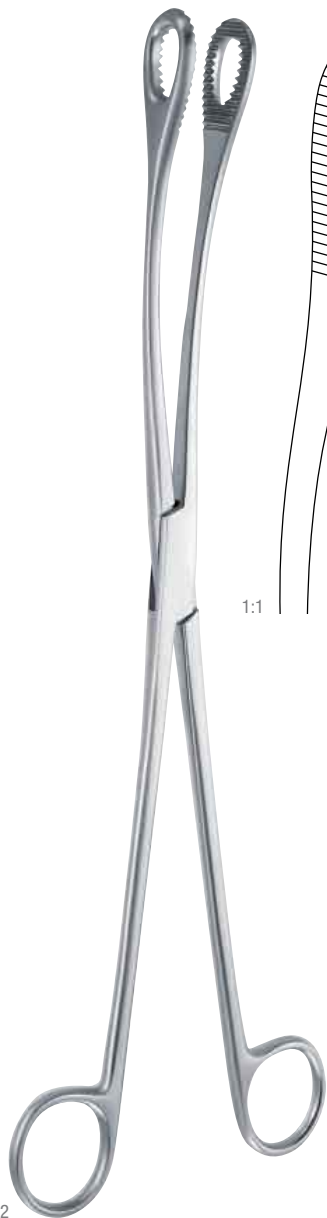

1:2

KELLY

320 mm – 12½" 369-539-320



1:2

NOTO

270 mm – 10¾" 369-536-270



1:2

DOYEN

200 mm – 8" 16-620-200

Uterusfazzangen
Uterine seizing forceps
Pinces hystérolabes
Histerólabos
Pinze isterolabi

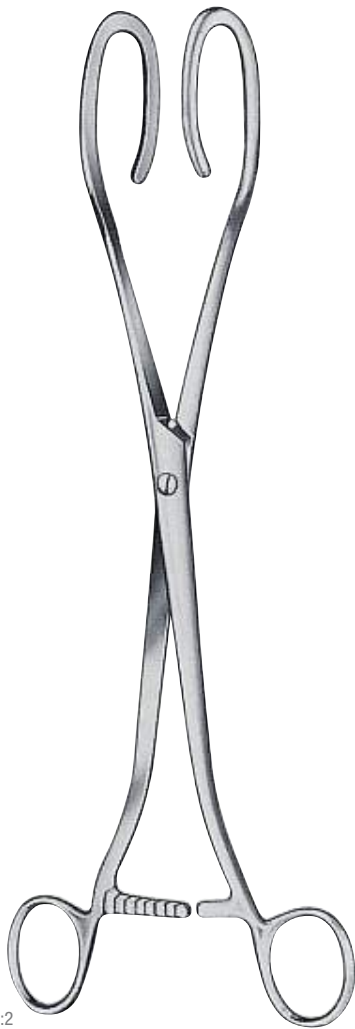

1:2

DARTIGUES

270 mm – 10¾"	16-630-270
---------------	------------



1:2

SOMER

230 mm – 9"	16-635-230
-------------	------------



1:2

COLLIN

250 mm – 9¾"	16-640-250
--------------	------------

Myom-Instrumente
Myoma instruments

Instruments pour myomes
Instrumentos para fibroma
Strumenti per miomi

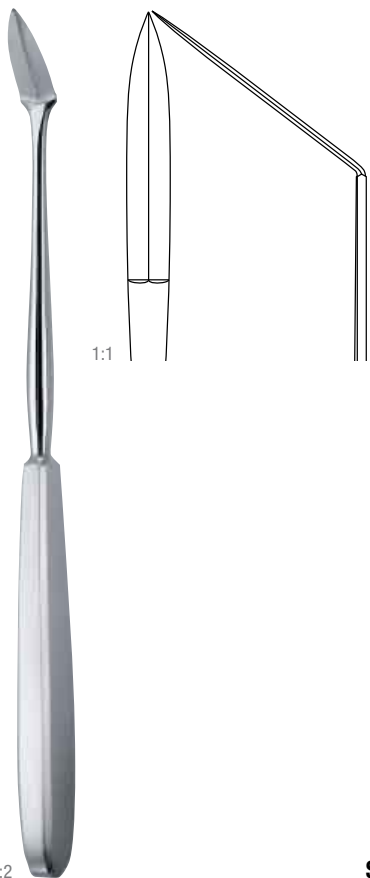

AYRE 1:2

235 mm – 9"

01-795-235

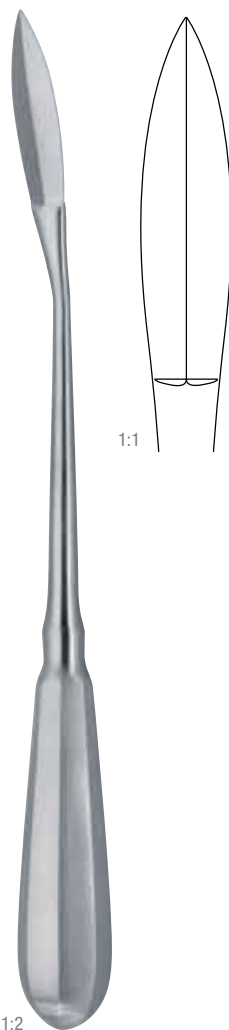

SEGOND 1:2

270 mm – 10 3/4"

01-799-270

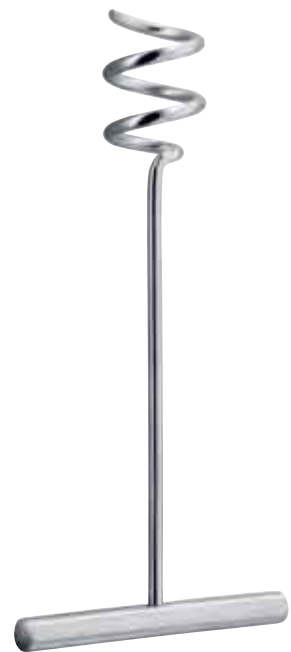

DOYEN 1:2

170 mm – 6 3/4"

61-552-170

Fistelhaken
Fistula hooks
Crochets pour fistules
Ganchos para fistulas
Uncini per fistole



SIMON

	Fig. 1	Fig. 2
220 mm – 8 3/4"	23-827-001	23-827-002



EMMET



	Fig. 1	Fig. 2
220 mm – 8 3/4"	23-821-001	23-821-002



	Fig. 3	Fig. 4
220 mm – 8 3/4"	23-821-003	23-821-004



	Fig. 5
220 mm – 8 3/4"	23-821-005

Probeexzisionszangen

Cervical biopsy and specimen forceps

Pinces emporte-pièces à biopsie

Pinzas saca-bocados para biopsia

Pinze taglianti per biopsia



SCHUBERT

210 mm – 8½"	369-600-210
280 mm – 11"	369-600-280



FAURE

210 mm – 8½"	369-597-210
--------------	-------------



SCHUBERT

260 mm – 10¼"	61-813-260
---------------	------------

Probeexzisionszangen

Cervical biopsy and specimen forceps

Pinces emporte-pièces à biopsie

Pinzas saca-bocados para biopsia

Pinze taglianti per biopsia



1:2

GELLHORN

230 mm – 9"

61-801-230



THOMS-GAYLOR

220 mm – 8¾"

61-811-220

240 mm – 9½"

61-811-240

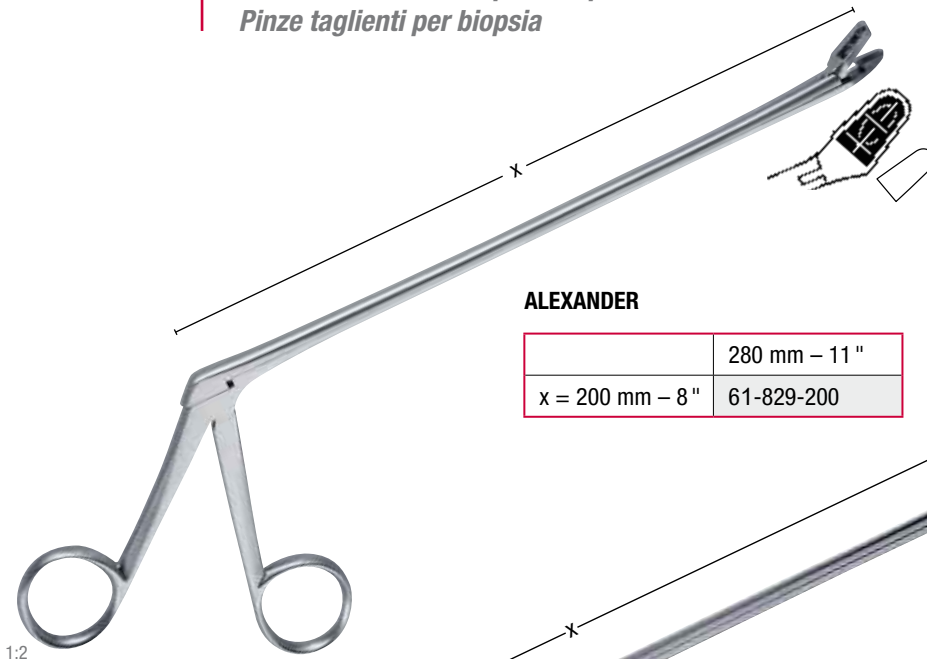
Probeexzisionszangen
Cervical biopsy and specimen forceps
Pinces emporte-pièces à biopsie
Pinzas saca-bocados para biopsia
Pinze taglienti per biopsia

ALEXANDER

	280 mm – 11 "
x = 200 mm – 8 "	61-829-200

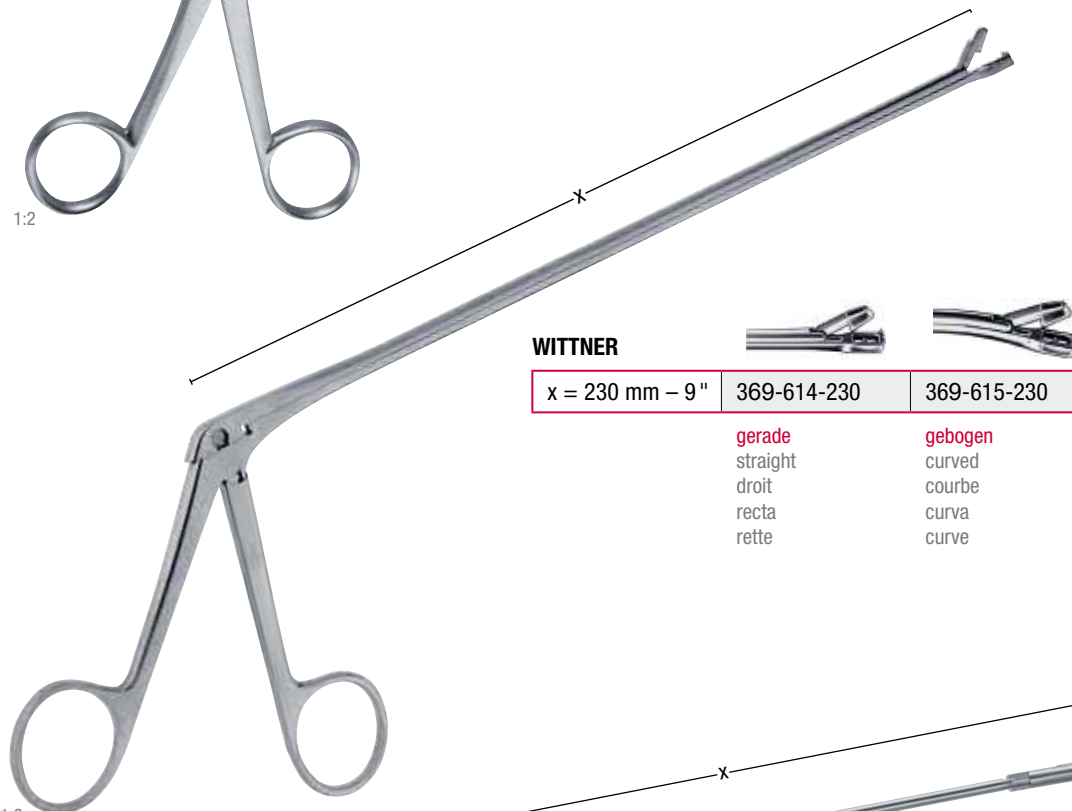
1:2



WITNER

x = 230 mm – 9 "	369-614-230	369-615-230
------------------	-------------	-------------

gerade
 straight
 droit
 recta
 rette

gebogen
 curved
 courbe
 curva
 curve

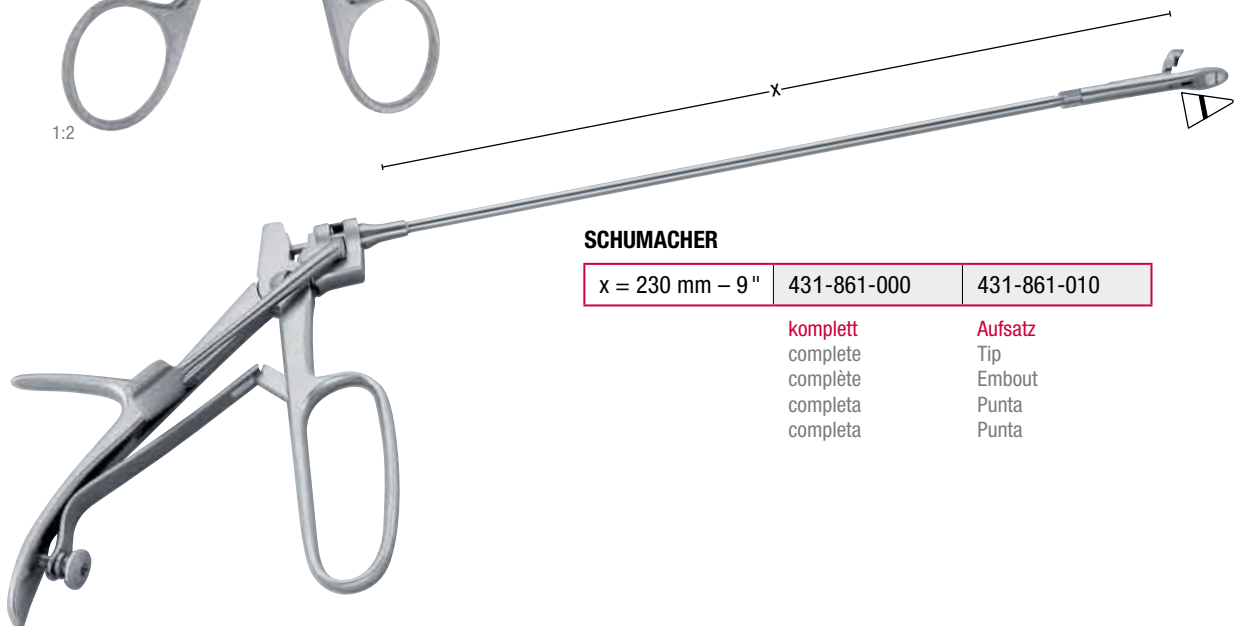
1:2

SCHUMACHER

x = 230 mm – 9 "	431-861-000	431-861-010
------------------	-------------	-------------

komplett
 complete
 complète
 completa
 completa

Aufsatz
 Tip
 Embout
 Punta
 Punta

1:2

Probeexzisionszangen

Cervical biopsy and specimen forceps

Pinces emporte-pièces à biopsie

Pinzas saca-bocados para biopsia

Pinze taglienti per biopsia

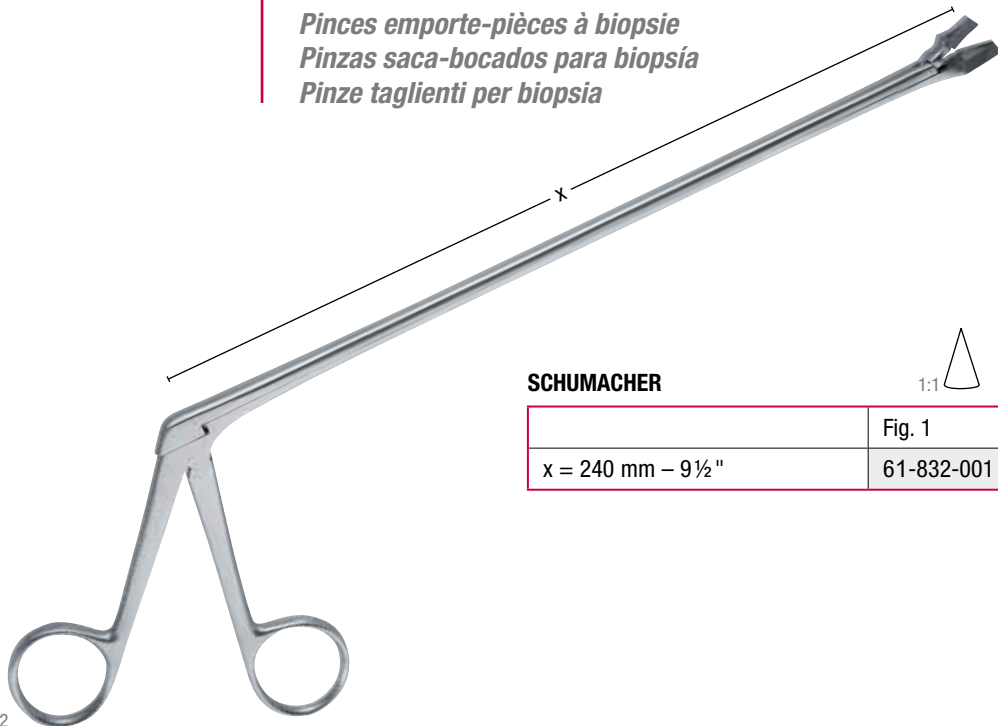

SCHUMACHER



	Fig. 1	Fig. 2
x = 240 mm – 9½"	61-832-001	61-832-002

1:2



1:2

VAN DOREN

250 mm – 9¾"
61-819-250



1:2

SCHUMACHER



	Fig. 1	Fig. 2
240 mm – 9½"	61-823-001	61-823-002

Probeexzisionszangen

Cervical biopsy and specimen forceps

Pinces emporte-pièces à biopsie

Pinzas saca-bocados para biopsia

Pinze taglienti per biopsia

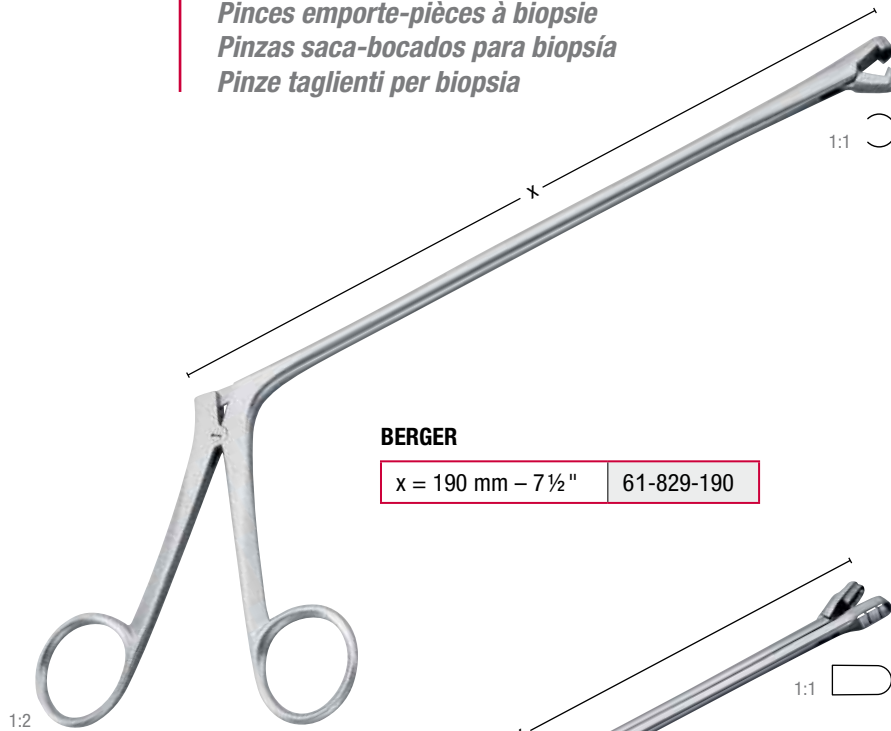

BERGER

x = 190 mm – 7 ½"

61-829-190

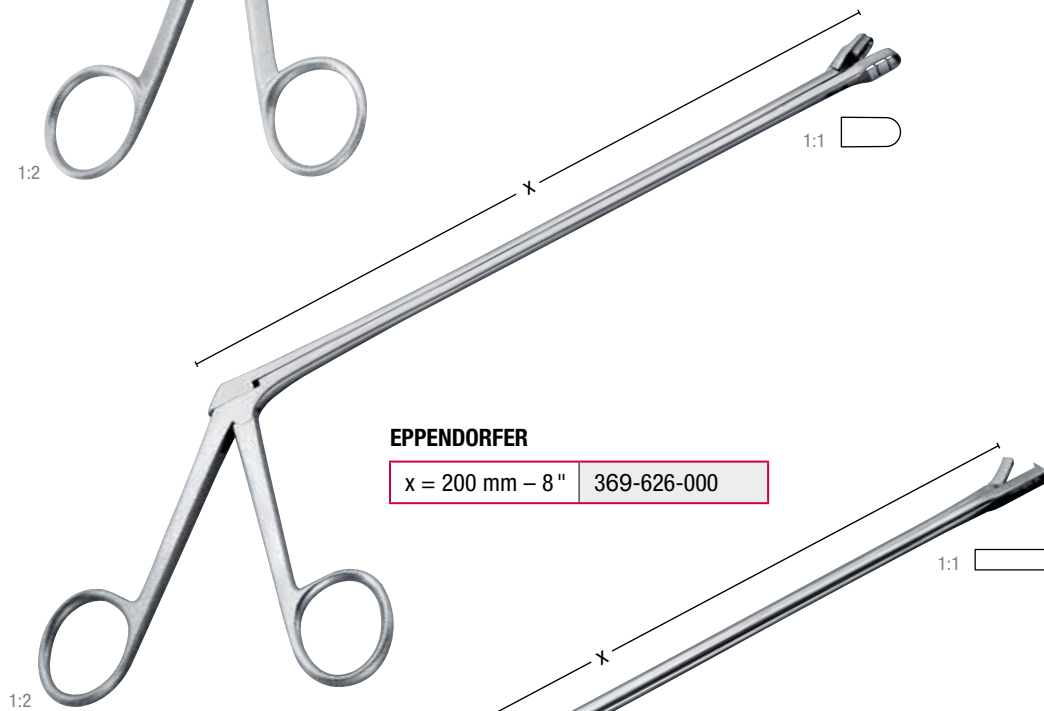

EPPENDORFER

x = 200 mm – 8"

369-626-000

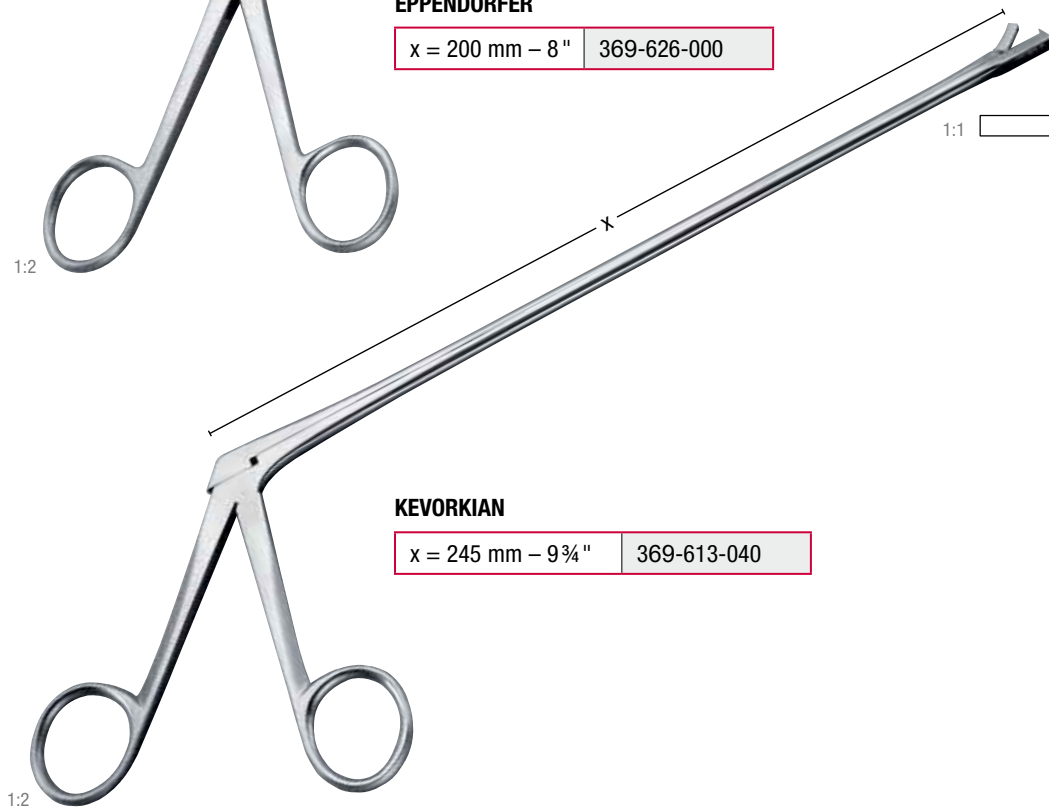

KEVORKIAN

x = 245 mm – 9 ¾"

369-613-040

Probeexzisionszangen

Cervical biopsy and specimen forceps

Pinces emporte-pièces à biopsie

Pinzas saca-bocados para biopsia

Pinze taglianti per biopsia



TISCHLER-MORGAN
USA MODELL

TISCHLER-
MORGAN

x = 200 mm – 8 "	369-609-001	369-617-000
x = 250 mm – 9 ¾ "	369-609-002	369-617-010

Instrument wie abgebildet, jedoch ohne Feststellschraube
 Instrument as illustrated, but without locking screw
 Instrument comme illustré, mais sans vis de fixation
 Instrumento según ilustración, pero sin tornillo de fijación
 Pinza come illustrata però senza vite di fissaggio

Probeexzisionszangen

Cervical biopsy and specimen forceps

Pinces emporte-pièces à biopsie

Pinzas saca-bocados para biopsia

Pinze taglianti per biopsia



MINI-TISCHLER
USA MODELL

MINI-
TISCHLER

x = 200 mm – 8"	369-611-001	369-617-030
x = 250 mm – 9¾"	369-611-002	369-617-020

Instrument wie abgebildet, jedoch ohne Feststellschraube
Instrument as illustrated, but without locking screw
Instrument comme illustré, mais sans vis de fixation
Instrumento según ilustración, pero sin tornillo de fijación
Pinza come illustrata però senza vite di fissaggio

Probeexzisionszangen
Cervical biopsy and specimen forceps
Pinces emporte-pièces à biopsie
Pinzas saca-bocados para biopsia
Pinze taglienti per biopsia



TISCHLER-MORGAN

3 x 7 mm	369-620-110
----------	-------------

gerade, Aufsatz allein
 straight, Tip only
 droit, mors seul
 recta, boca sola
 retta, punta sola



TOWNSEND

3 x 7 mm	369-620-020
----------	-------------

aufwärts, Aufsatz allein
 up, Tip only
 haut, mors seul
 arriba, boca sola
 in alto, punta sola



TOWNSEND

3 x 7 mm	369-620-010
----------	-------------

abwärts, Aufsatz allein
 down, Tip only
 bas, mors seul
 abajo, boca sola
 in basso, punta sola

369-620-002

Uni-Griff allein
 Handle only
 Poignee seule
 Mango sólo
 Manico solo



TOWNSEND-MINI

2.3 x 4 mm	369-620-060
------------	-------------

gerade, Aufsatz allein
 straight, Tip only
 droit, mors seul
 recta, boca sola
 retta, punta sola



TOWNSEND-MINI

2.3 x 4 mm	369-620-070
------------	-------------

aufwärts, Aufsatz allein
 up, Tip only
 haut, mors seul
 arriba, boca sola
 in alto, punta sola



369-620-004

Uni-Griff allein mit Ring
 Handle only
 Poignee seule
 Mango sólo
 Manico solo



TOWNSEND-MINI

2.3 x 4 mm	369-620-050
------------	-------------

abwärts, Aufsatz allein
 down, Tip only
 bas, mors seul
 abajo, boca sola
 in basso, punta sola



TOWNSEND-KEVORKIAN

3 x 9 mm	369-620-040
----------	-------------

Aufsatz allein
 Tip only
 Mors seul
 Boca sola
 Punta sola



TOWNSEND-OVAL

3 x 5 mm	369-620-030
----------	-------------

Aufsatz allein
 Tip only
 Mors seul
 Boca sola
 Punta sola



BURKE

3 x 5 mm	369-620-080
----------	-------------

Aufsatz allein
 Tip only
 Mors seul
 Boca sola
 Punta sola

Biopsieküretten
Biopsy curettes
Curettes pour biopsie
Curetas para biopsía
Curette per biopsia

KEVORKIAN

	1.2 mm Ø	1.2 mm Ø
300 mm – 12"	369-590-120	369-592-120

fest, ohne Korb
 rigid, without basket
 rigide, sans panier
 rigida, sin cesta
 rigida, senza cestino

fest, mit Korb
 rigid, with basket
 rigide, avec panier
 rigida, con cesta
 rigida, con cestino

4 mm Ø	4 mm Ø
369-590-400	369-592-400

biegsam, ohne Korb
 malleable, without basket
 malléable, sans panier
 maleable, sin cesta
 flessibile, senza cestino

biegsam, mit Korb
 malleable, with basket
 malléable, avec panier
 maleable, con cesta
 flessibile, con cestino



RANDALL

	4 mm Ø
240 mm – 9½"	61-725-240



NOVAK

	4 mm Ø
230 mm – 9"	61-721-230

MINI-NOVAK

	235 mm – 9¼"
1 mm Ø	369-588-010
2 mm Ø	369-588-020
3 mm Ø	369-588-030
4 mm Ø	369-588-040

Absaugküretten
Aspirating currettes
Curettes d'aspiration
Curetas de aspiración
Curette per aspirazione



	200 mm – 11 ½ "
3 mm Ø	431-985-030
4.5 mm Ø	431-985-040
6 mm Ø	431-985-060
8 mm Ø	431-985-080
10 mm Ø	431-985-100
12 mm Ø	431-985-120
14 mm Ø	431-985-140

Probe- und Absaugkürette
 Specimen and aspirating curette
 Curette à biopsies et d'aspiration
 Cureta de biopsia y de aspiración
 Curette per biopsia ed per aspirazione



120 mm – 4 ¾ "	431-985-500
----------------	-------------

Kupplungsstück
 Coupling piece
 Pièce d'accouplement
 Pieza de conexión
 Pezzo di connessione

1:2

Salpingograph
Salpingograph
Salpingographe
Salpingógrafo
Salpingografo

SCHULTZE

295 mm – 11 ½"	61-980-000
----------------	------------

Salpingograph, komplett im Holzetui
 Salpingograph, complete in wooden case
 Salpingographe, complet en etui de bois
 Salpingógrafo, completa en caja de madera
 Salpingografo, completo in astuccio di legno

61-980-001

Manometer alleine
 Manometer only
 Manomètre seule
 Manómetro sólo
 Manometro solo

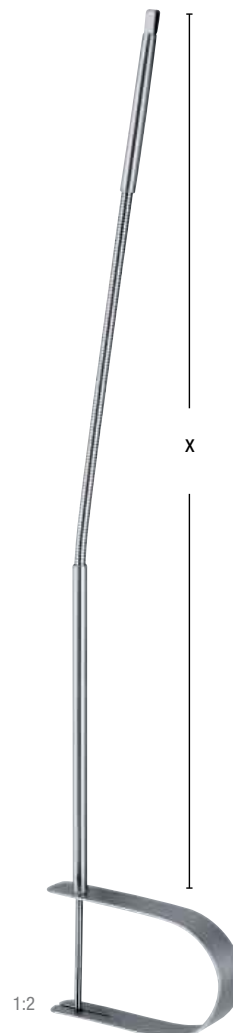

	4 mm Ø
x = 230 mm – 9"	369-552-300

Zange zum Entfernen von Spiralen

Forceps for I.U.D. removings
 Pince pour enlever des stérilets
 Pinza para remover la espiral de esterilidad
 Pinza per distaccare la spirale

1:2

Uterusküretten
Uterine curettes

Curettes utérines
Curetas uterinas
Curette uterine

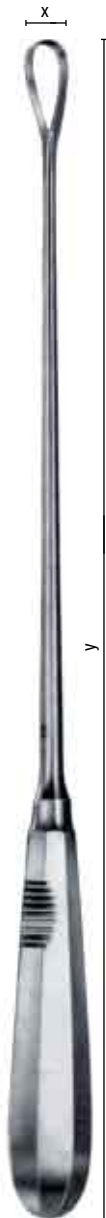
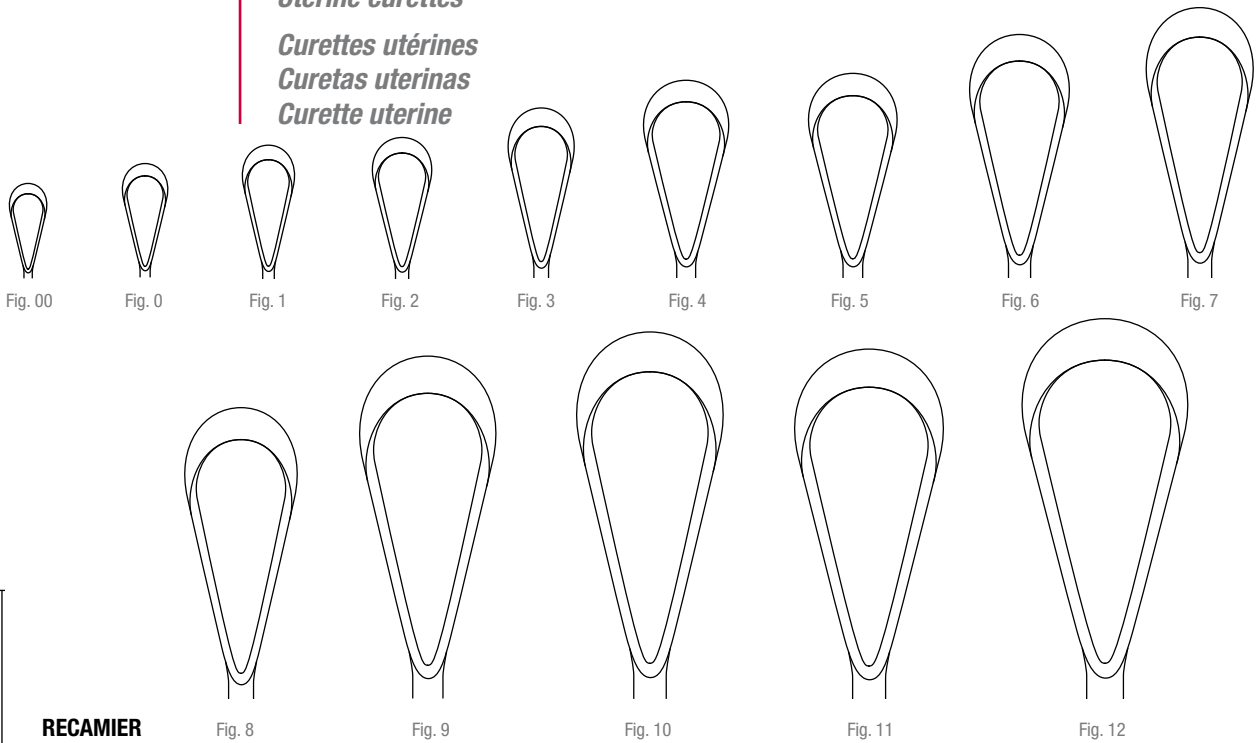

RECAMIER

$y = 260 \text{ mm} - 10\frac{1}{4}''$	Fig.	mm				
	00	5	61-740-002	61-742-002	61-750-002	61-752-002
	0	6	61-740-003	61-742-003	61-750-003	61-752-003
	1	7	61-740-010	61-742-010	61-750-010	61-752-010
	2	8	61-740-020	61-742-020	61-750-020	61-752-020
	3	9	61-740-030	61-742-030	61-750-030	61-752-030
	4	11	61-740-040	61-742-040	61-750-040	61-752-040
	5	12	61-740-050	61-742-050	61-750-050	61-752-050
	6	14	61-740-060	61-742-060	61-750-060	61-752-060
	7	15	61-740-070	61-742-070	61-750-070	61-752-070
	8	16	61-740-080	61-742-080	61-750-080	61-752-080
	9	19	61-740-090	61-742-090	61-750-090	61-752-090
	10	20	61-740-100	61-742-100	61-750-100	61-752-100
	11	21	61-740-110	61-742-110	61-750-110	61-752-110
	12	23	61-740-120	61-742-120	61-750-120	61-752-120
$y = 310 \text{ mm} - 12\frac{1}{4}''$	Fig.	mm				
	00	5	61-744-002	61-746-002	61-754-002	61-756-002
	0	6	61-744-003	61-746-003	61-754-003	61-756-003
	1	7	61-744-010	61-746-010	61-754-010	61-756-010
	2	8	61-744-020	61-746-020	61-754-020	61-756-020
	3	9	61-744-030	61-746-030	61-754-030	61-756-030
	4	11	61-744-040	61-746-040	61-754-040	61-756-040
	5	12	61-744-050	61-746-050	61-754-050	61-756-050
	6	14	61-744-060	61-746-060	61-754-060	61-756-060
	7	15	61-744-070	61-746-070	61-754-070	61-756-070
	8	16	61-744-080	61-746-080	61-754-080	61-756-080
	9	19	61-744-090	61-746-090	61-754-090	61-756-090
	10	20	61-744-100	61-746-100	61-754-100	61-756-100
	11	21	61-744-110	61-746-110	61-754-110	61-756-110
	12	23	61-744-120	61-746-120	61-754-120	61-756-120

scharf, starr
sharp, rigid
tranchante, rigide
cortante, rígida
tagliente, rigida

scharf, biegsam
sharp, malleable
tranchante, malléable
cortante, maleable
tagliente, flessibile

stumpf, starr
blunt, rigid
mousse, rigid
roma, rígida
smussa, rigida

stumpf, biegsam
blunt, malleable
mousse, malléable
roma, maleable
smussa, flessibile

Uterusküretten

Uterine curettes

Curettes utérines

Curetas uterinas

Curette uterine

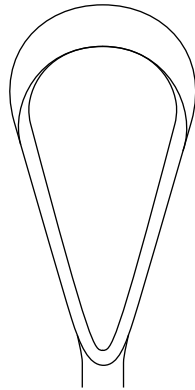

Fig. 13

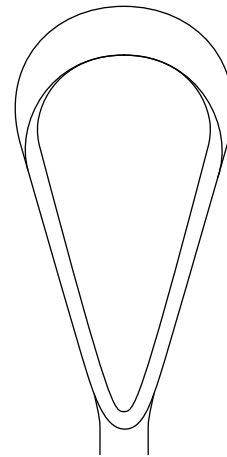

Fig. 14

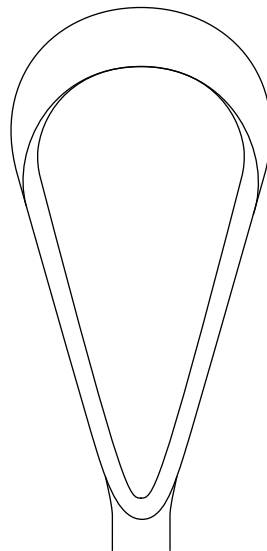

Fig. 15

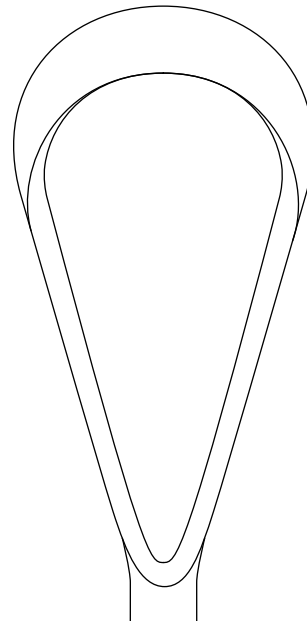

Fig. 16

RECAMIER

y = 340 mm – 13½"	Fig.	x = mm				
	13	25	61-744-130	61-746-130	61-754-130	61-756-130
	14	30	61-744-140	61-746-140	61-754-140	61-756-140
	15	35	61-744-150	61-746-150	61-754-150	61-756-150
	16	40	61-744-160	61-746-160	61-754-160	61-756-160

scharf, starr
sharp, rigid
tranchante, rigide
cortante, rigida
tagliante, rigida

scharf, biegsam
sharp, malleable
tranchante, malléable
cortante, maleable
tagliante, flessibile

stumpf, starr
blunt, rigid
mousse, rigid
roma, rigida
smussa, rigida

stumpf, biegsam
blunt, malleable
mousse, malléable
roma, maleable
smussa, flessibile

Scharfe Löffel
Uterine spoons

Curettes tranchantes
Cucharillas cortantes
Cucchiai taglienti



SIMON

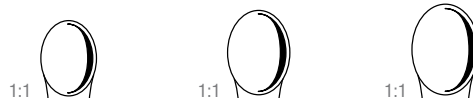

	Fig. 1	Fig. 2	Fig. 3
250 mm – 9 3/4"	61-610-001	61-610-002	61-610-003

scharf, fest
 sharp, rigid
 tranchante, rigide
 cortante, rígida
 taglienti, rigido

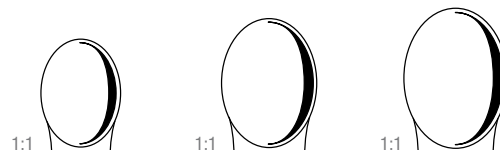

Fig. 4	Fig. 5	Fig. 6
61-610-004	61-610-005	61-610-006



SCHRÖDER

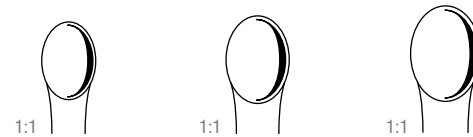

	Fig. 1	Fig. 2	Fig. 3
300 mm – 12"	61-612-001	61-612-002	61-612-003

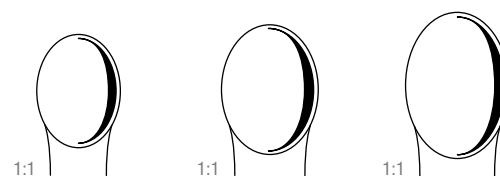

Fig. 4	Fig. 5	Fig. 6
61-612-004	61-612-005	61-612-006

Geburtszangen

Obstetrical forceps

Forceps obstétriques

Forceps obstétricos

Forcipi



SIMPSON

1:3

300 mm – 12"	63-301-300
--------------	------------



**SIMPSON-
BRAUN**

330 mm – 13"	371-101-330
360 mm – 14 ¼"	63-305-360



NAEGELE

360 mm – 14 ¼"	63-341-360
400 mm – 16"	63-341-400



PIPER

1:3

440 mm – 17 ¼"	63-351-440
----------------	------------

Geburtszangen
Obstetrical forceps
Forceps obstétriques
Forceps obstétricos
Forcipi



**SIMPSON-
LUIKART**

1:3

360 mm – 14 ¼"	371-131-360
----------------	-------------



WRIGLEY

1:3

230 mm – 9"	371-097-230
-------------	-------------

für Kaiserschnitt
 for caesarian section
 pour césarienne
 para operación cesárea
 per taglio cesareo



DE LEE

1:3

300 mm – 12"	371-103-300
--------------	-------------



DE LEE

360 mm – 14 ¼"	371-104-360
390 mm – 15 ½"	371-104-390

Geburtszangen

Obstetrical forceps

Forceps obstétriques

Forceps obstétricos

Forcipi



ELLIOT

320 mm – 12 ½"	63-311-320
380 mm – 15"	63-311-380



MCLEAN 1:3

360 mm – 14 ¼"	371-141-360
----------------	-------------



KIELLAND 1:3

410 mm – 16 ¼"	63-331-410
----------------	------------



KIELLAND-LUIKART 1:3

400 mm – 16"	371-123-400
--------------	-------------

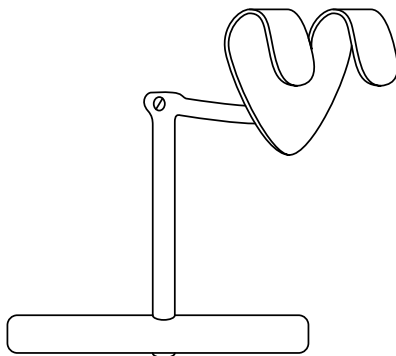

BILL

63-381-000

Zughebel, passend für alle Geburtszangen mit gehornem Standard-Griff
Traction handle for all the forceps with horned standard handle
Dispositif de traction pour tous les forceps avec manche normal à cornes
Dispositivo de tracción para todos los forceps con mango standard con curva
Impugnatura di trazione adatto a tutti i forcipi con manico standard con corne

Geburtshilfe
Obstetrics
Obstétrique
Obstetricia
Ostetricia



SELLHEIM 1:2
 280 mm – 11" | 371-255-280

Geburtslöffel
 Obstetric lever
 Cuillère obstétricale
 Cuchara obstétrica
 Cucchaio obstetrico

BRAUN 1:2
 300 mm – 12" | 63-451-300

Dekapitationshaken
 Decapitating hook
 Crochet de décapitation
 Gancho de descapitación
 Uncino di decapitazione

1:2
GREEN-ARMYTAGE
 210 mm – 8 ¼" | 16-650-210

Uterusklemmzange
 Uterine elevating forceps
 Pince utérine
 Pinza para el útero
 Pinza uterina

Geburtshilfe
Obstetrics
Obstétrique
Obstétrica
Ostetricia



SMELLIE 1:3

250 mm – 10"	63-420-250
--------------	------------

Perforatorium
Perforator
Perforateur
Perforador
Perforatore



BRAUN 1:3

420 mm – 16 ½"	63-501-420
----------------	------------

Kranioklast, ein Maul gefenstert
Cranioclast, one jaw fenestrated
Cranioclasse, une partie fenestrée
Craneolasto, una boca fenestrada
Cranioclasse, un lato fenestrato



TARNIER 1:3

460 mm – 17 ¼"	63-506-460
----------------	------------

Basiotribe
Basiotribe
Basiotribe
Basiotribo
Basiotribo

Abortuszangen – Abortusküretten

Abortion forceps – Ovum curettes

Pinces à faux germes – Curette d'avortement

Pinzas para aborto – Curetas para aborto

Pinze per placenta ed aborto – Curette per placenta ed aborto



WINTER

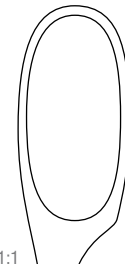
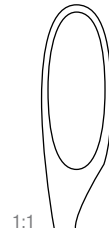

	Fig. 1	Fig. 2	Fig. 3
280 mm – 11 "	16-666-001	16-666-002	16-666-003

gerade
straight
droit
recta
rette

16-667-001	16-667-002	16-667-003
------------	------------	------------

gebogen
curved
courbe
curva
curve



CUZZI

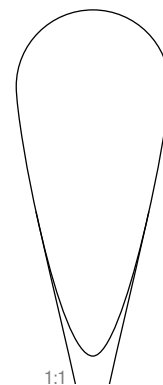
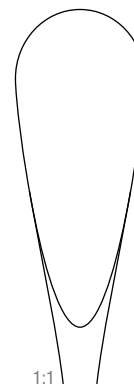
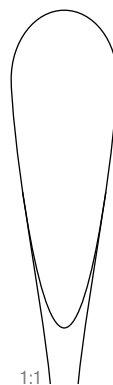
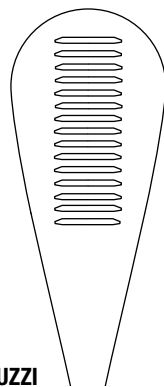

	14.5 mm	18.0 mm	21.0 mm
300 mm – 12 "	371-250-140	371-250-180	371-250-210

stumpf, Rückseite gerieft
blunt, back serrated
mousse, dos strié
romo, dorso estriado
smusso, dorso zigrinato

Abortuszangen – Abortusküretten
Abortion forceps – Ovum curettes
Pinces à faux germes – Curette d'avortement
Pinzas para aborto – Curetas para aborto
Pinze per placenta ed aborto – Curette per placenta ed aborto



1:2

SAENGER

270 mm – 10¾"

16-660-270

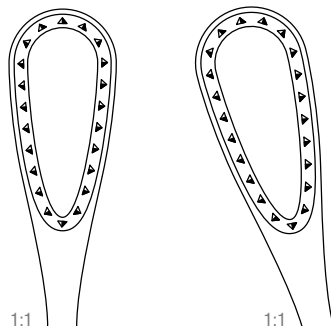
16-661-270



1:1

1:1



PESTALOZZA

300 mm – 12"

371-248-300

1:3

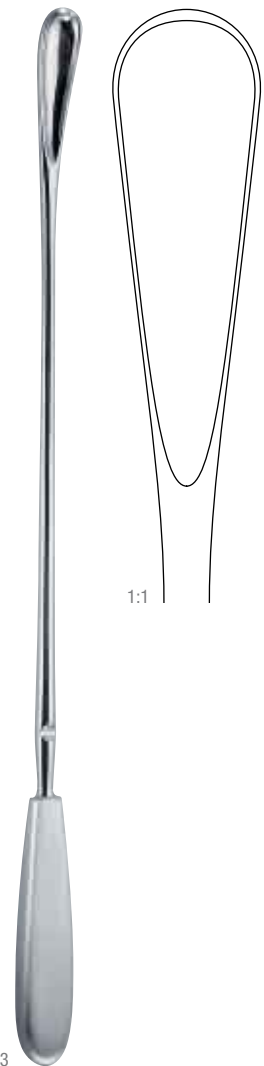
1:1

WALLICH

420 mm – 16½"

371-252-420

1:3

1:1

 stumpf
 blunt
 mousse
 roma
 smussa

Nabelschnurklemmen
Umbilical cord clamps

Clamps pour le cordon ombilical
Clamps umbilicales
Pinze ombelicali

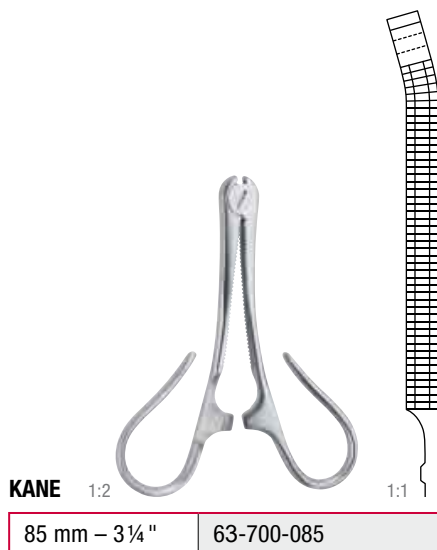

Beckenzirkel
Pelvimeters
Pelvimètres
Pelvímetros
Pelvimetri



MARTIN

1:3

340 mm – 13 ½"	63-121-340
----------------	------------

cm / Zoll-Scala
cm / inch-scale
échelle en cm / pouces
escala cm / pulgadas
scala cm / pollici



COLLIN

1:3

350 mm – 13 ¾"	371-191-350
----------------	-------------

cm-Scala
cm-scale
échelle en cm
escala en cm
scala in cm