

12

Diagnostik, Narkose

Diagnostics, Anaesthesia

Diagnostic, Anesthésie

Diagnóstico, Anestesia

Diagnostica, Anestesia



Perkussionshämmer
Percussion Hammers
Marteaux-percuteurs
Martillos de percusión
Martelli percussori



BABINSKY

220 mm – 8 3/4"	35-120-240
-----------------	------------



RABINER

230 mm – 9"	416-146-230
-------------	-------------

Perkussionshämmer
Percussion Hammers
Marteaux-percuteurs
Martillos de percusión
Martelli percussori



WARTENBERG

1:2

190 mm – 7"

35-194-190



BUCK

1:2

180 mm – 7"

1:1

35-140-180



TROEMNER

1:2

240 mm – 9½"

35-150-240

Perkussionshämmer
Percussion Hammers
Marteaux-percuteurs
Martillos de percusión
Martelli percussori



TAYLOR

180 mm – 7"	416-188-180
200 mm – 8"	35-170-200



BERLINER

170 mm – 6"	301-302-170
200 mm – 8"	301-302-200



DÉJERINE 1:1

210 mm – 8"	301-300-200
-------------	-------------

1:2

Diagnostik-Bestecke
Diagnostic sets

Trousses à diagnose
Juegos para diagnóstico
Astucci diagnostici

35-780-002

Ophthalmoskop-Besteck
Ophthalmoscope set
Trousse à ophtalmoscopie
Oftalmoscopio
Oftalmoscopio



35-740-002

Universal-Besteck
Universal set
Trousse universelle
Estuche universal
Astuccio universale



Diagnostik-Bestecke
Diagnostic sets

Trousses à diagnose
Juegos para diagnóstico
Astucci diagnostici



35-760-002

Kombinations-Besteck
Combination set
Trousse combinée
Estuche combinado
Astuccio combinato



35-790-002

Otoskop-Besteck
Otoscope set
Trousse à otoscopie
Otoscopio
Otoscopio

Stethoskope
Stethoscopes
Stéthoscopes
Estetoscopios
Stetoscopi

PINARD

180 mm – 7"	35-206-180
240 mm – 9½"	35-206-240

Holz
 Wood
 Bois
 Madera
 Legno

PINARD 1:2

150 mm – 6"	35-210-150
-------------	------------

Aluminium
 Aluminium
 Aluminium
 Aluminio
 Alluminio

DUPLEX

47 mm	35-260-000
-------	------------

für Erwachsene
 for adults
 pour adultes
 para adultos
 per adulti

DUPLEX-COLOR

1:4

35-262-000	35-264-000	35-266-000	35-268-000
------------	------------	------------	------------

blau
 blue
 bleu
 azul
 azzurro

grün
 green
 vert
 verde
 verde

gold
 gold
 couleur d'or
 color de oro
 topazio

rot
 red
 rouge
 rojo
 rosso

Stethoskope
Stethoscopes
Stéthoscopes
Estetoscopios
Stetoscopi



BABY-DUPLEX

1:4

37 mm	35-232-000	35-232-002
-------	------------	------------

in Karton
 in card board box
 en carton
 en caja de cartón
 a cartone

in Plastiktasche
 in plastic storage pouch
 en étui plastique
 en estuche de plástico
 a plastica borsa

NEONATAL-DUPLEX

35-232-004	35-232-006
------------	------------

in Karton
 in card board box
 en carton
 en caja de cartón
 a cartone

in Plastiktasche
 in plastic storage pouch
 en étui plastique
 en estuche de plástico
 a plastica borsa



1:1

ANESTOPHON-COLOR

47 mm	35-270-100	35-272-100	35-274-100	35-276-100	35-278-100
-------	------------	------------	------------	------------	------------

für Schwestern, einfach
 for nurses, simple
 pour infirmières, simple
 para enfermeras, simple
 per infermiere, semplice

blau
 blue
 bleu
 azul
 azzurro

grün
 green
 vert
 verde
 verde

gold
 gold
 couleur d'or
 color de oro
 topazio

silber
 silver
 argentín
 plateado
 argenteo

rot
 red
 rouge
 rojo
 rosso



1:4

Stirnspiegel
Head mirrors
Miroirs frontaux
Espejos frontales
Specchi frontali

ZIEGLER

90 mm Ø	35-920-090
100 mm Ø	35-920-100

Stirnspiegel mit schwarzem Plastikband

Head mirror with black plastic head band
 Miroir frontal avec ruban en plastique noir
 Espejo frontal con banda de plástica negra
 Specchio frontale con fascia di plastica nera

ZIEGLER

90 mm Ø	35-928-090
100 mm Ø	35-928-100

Reflexspiegel allein, mit Gummifassung

Head mirror only, with rubber coating
 Miroir frontal seul, avec monture en caoutchouc
 Espejo frontal sólo, con guarnición de goma
 Solo specchio frontale, con guarnizione di gomma

90 mm Ø	416-448-090
100 mm Ø	416-448-100

Stirnspiegel mit weissem Plastikband

Head mirror with white plastic head band
 Miroir frontal avec ruban en plastique blanc
 Espejo frontal con banda de plástica blanca
 Specchio frontale con fascia di plastica bianca

36-920-000	416-468-000
------------	-------------

Plastikband, schwarz

Black plastic head band
 Ruban en plastique noir
 Banda de plástica, negra
 Fascia di plastica, nera

Plastikband, weiss

White plastic head band
 Ruban en plastique blanc
 Banda de plástica, blanca
 Fascia di plastica, bianca

Kaltlicht-Stirnlampe
Cold-light head lamp

Eclaireur frontal de lumière froide
Lámpara frontal de luz fría
Lámpara frontale a luce fredda



BINNER

35-938-000

**Kaltlicht-Stirnlampe mit verstellbarer Fokussierlinse,
Arbeitsabstand 300 mm, Leuchtfeldgröße 70 – 120 mm Ø**
Head light, cold-light, adjustable focus,
working distance 300 mm, field of illumination 70 – 120 mm Ø
Eclaireur frontal, lumière froide, focus ajustable,
distance de travail 300 mm, champ d'illumination 70 – 120 mm Ø
Lámpara frontal, luz fría, focus ajustable,
distancia de trabajo 300 mm, campo de iluminación 70 – 120 mm Ø
Lampada frontale, luce fredda, con lente a focale variabile,
distanza di lavoro 300 mm, campo d'illuminazione 70 – 120 mm Ø

Stirnlampen
Head lamps
Eclaireurs frontaux
Lámparas frontales
Lampade frontali

1:3

CLAR

100 mm Ø, 6 V	416-516-060
---------------	-------------

Stirnlampe komplett
Head light complete
Eclaireur frontal complet
Lámpara frontal, completa
Lampada frontale, completa

100 mm Ø, 6 V	416-520-060
---------------	-------------

Stirnlampe mit Kabel, Fassung und Spiegel, ohne Stirnreifen
Head light with cable, frame and mirror, without head band
Eclaireur frontal avec cable, douille et miroir, sans ruban
Lámpara frontal, con cable, armadura y espejo, sin banda
Lampada frontale con cavo, supporto e specchio, senza fascia

1:3

MINI-CLAR

50 mm Ø, 6 V	416-524-060
--------------	-------------

komplett
complete
complet
completa
completa
CLAR

416-521-020

Spezial-Gelenkverbindung
Special socket joint
Assemblage articulé spécial
Conexión
Giunto di connessione speciale
CLAR

416-522-010

Stirnreifen allein
Head band only
Ruban seul
Banda sola
Solo fascia frontale
CLAR

50 mm Ø	35-940-003
---------	------------

100 mm Ø	35-940-002
----------	------------

Spiegel aus Glas, ohne Fassung
Head mirror glass, without frame
Miroir frontal en vitre, sans douille
Espejo frontal de cristal, sin armadura
Vetro specchio, senza supporto

6 V	301-195-060
-----	-------------

Glühbirne
Bulb
Ampoule
Bombilla
Lampadina

Stirnlampen

Head lamps

Eclaireurs frontaux

Lámparas frontales

Lampade frontali



Input 220 V/50 Hz ~

Output 0 – 10 V/3 W =

416-574-010

Transformator – stufenlos einstellbar
Transformer – stepless adjustable
Transformateur – à réglage continu
Transformador – regulación continua
Trasformatore – regolabile in continuità

Binokularlupe

Binocular magnifying lens

Loupe binoculaire

Lupa binocular

Lente binoculare



416-608-000

2.5 fache Vergrößerung, 340 mm Arbeitsabstand, Sichtfeld > 90 mm Ø, komplett.
Pupillenabstand einstellbar von 48 mm – 77 mm. Neigungswinkel individuell justierbar.
Gewicht der Optik 42 g.

2.5 times enlargement, 340 mm working distance, field of vision > 90 mm Ø, complete.
Pupillary distance adjustable from 48 mm – 77 mm. Individual adjustable angle of inclination.
Weight of the optic 42 g.

2.5 fois grossissement, distance de travail 340 mm, champ de vision > 90 mm Ø, complet.
Ecart interpupillaire ajustable de 48 mm – 77 mm. Angle d'inclinaison ajustable individuellement.
Poids de l'optique 42 g.

2.5 veces aumento, distancia de trabajo 340 mm, campo de visión > 90 mm Ø, completo.
Distancia interpupilar ajustable de 48 mm – 77 mm. Angulo de inclinación ajustable individual.
Peso de la óptica 42 g.

Ingrandimento: 2.5 volte, distanza di lavoro 340 mm, campo di visione > 90 mm Ø, completo.
Distanza interpupillare regolabile da 48 mm – 77 mm. Angolo di inclinazione regolabile individualmente.
Peso dell'ottica 42 g.

416-608-010

Kopfband

Head band
Ruban
Banda
Fascia



Andere Arbeitsabstände und Sichtfelder auf Anfrage.

Other working distances and fields of vision upon request.
Autres distances de travail et champs de vision sur demande.
Otras distancias de trabajo y campos de visión según demanda.
Su richiesta disponibili altre distanze di lavoro e campi di visione

Blutdruckmessgeräte
Sphygmomanometers

Tensiomètres
Esignomanómetros
Sfigmomanometri



35-420-002

Quecksilber-Blutdruckmessapparat, geeicht
Mercury blood pressure manometer, calibrated
Tensiomètre à mercure, calibré
Manómetro de mercurio, calibrado
Manometro a mercurio, calibrato

35-460-000

ungeeicht
non calibrated
non calibré
no calibrado
non calibrato

Messinstrumente
Measuring instruments
Instruments pour mesurer
Instrumentos de medidas
Strumenti di misura

COLLIN

125 mm – 5"	35-620-001	35-620-002	416-406-030
	für Kinder, kg-Einteilung for children, kg-scale pour enfants, échelle en kg para niños, graduación en kg per bambini, graduazione in kg	für Erwachsene, kg-Einteilung for adults, kg-scale pour adultes, échelle en kg para adultos, graduación en kg per adulti, graduazione in kg	für Erwachsene, lbs-Einteilung for adults, lbs-scale pour adultes, échelle en lbs para adultos, graduación en lbs per adulti, graduazione in lbs

BERTILLON

1:3

320 mm – 12 ½"	301-306-010
----------------	-------------



1:2

MOELTGEN

240 mm – 9 ½"	35-640-000
---------------	------------

Messinstrumente
Measuring instruments
Instruments pour mesurer
Instrumentos de medidas
Strumenti di misura



VERNIER

1:2

210 mm – 8 ¼"	416-411-210	416-412-010
---------------	-------------	-------------

Aluminium
 Aluminium
 Aluminium
 Aluminio
 Alluminio

Stahl
 Steel
 Acier
 Acero
 Accaio



CASTROVIEJO

1:1

80 mm – 3 ¼"	41-850-020
--------------	------------

Messinstrumente
Measuring instruments
Instruments pour mesurer
Instrumentos de medidas
Strumenti di misura

1:3

500 mm – 20"	35-650-500
--------------	------------

Röntgen-Messstab

 X-ray ruler
 Règle rayons X
 Regla para rayos X
 Misuratore per raggi X

1:1

1500 mm – 60"	35-656-000	301-348-150
---------------	------------	-------------

Stahl
 Steel
 Acier
 Acero
 Acciaio

Wachs
 Wax cloth
 Toile cirée
 Cerada
 Cera

100 mm – 4"	301-336-100
150 mm – 6"	301-336-150
200 mm – 8"	301-336-200
300 mm – 12"	301-336-300
400 mm – 15 3/4"	301-336-400
500 mm – 20"	301-336-500

Zungenspatel
Tongue depressors
Abaisse-langues
Espátulas bucales
Abbassalingua



Packung mit 100 Stück
 Package of 100 pieces
 Paquet de 100 pièces
 Paquetes de 100 piezas
 Confezione da 100 pezzi



1:2

KROENIG

150 mm – 6" 437-375-150



1:2

145 mm – 5¾" 347-104-140



1:2

160 mm – 6¼" 47-250-160

Holz
 Wood
 Bois
 Madera
 Legno



1:2

MAYO

170 mm – 6¾" 437-378-170



1:2

BRUENINGS

190 mm – 7½" 47-255-190



1:2

FRENZEL

165 mm – 6½" 347-101-160

Zungendrucker
Tongue depressors
Abaisse-langues
Baja lenguas
Abbassalingua



WIEDER

1:2

1:2

150 mm – 6"		347-111-020
140 mm – 5½"	347-111-010	



BOSWOTH

1:2

145 mm – 5¾"	437-281-140
--------------	-------------



TOBOLD

1:2

145 mm – 5¾"	347-115-140
--------------	-------------



HARTMANN

1:2

150 mm – 6"	47-227-150
-------------	------------



ANDREW

1:2

110 mm – 4¾"	347-113-110
--------------	-------------

Zungenzangen
Tongue holding forceps
Pinces tire langue
Pinzas tiralengua
Pinze tiralingua



YOUNG

1:2

170 mm – 6 ¾"	16-331-170
---------------	------------

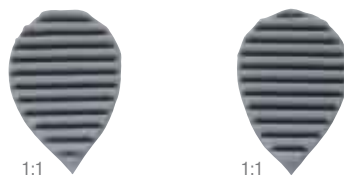

1:1

1:1

16-334-000

1 Paar Ersatz Gummi-Einsätze
 1 Pair rubber-inserts
 1 Paire des inserts en caoutchouc
 1 Juego de insertos de goma
 1 Paio d'inserti di gomma



COLLIN

160 mm – 6 ¼"	16-320-160
170 mm – 6 ¾"	16-324-170
190 mm – 7 ½"	16-324-190

Wangenhalter

Cheek retractors

Ecarteur des joues

Separador de mejillas

Divaricatori per guancia



STERNBERG

120 mm – 4 ¾ "	347-225-120
140 mm – 5 ½ "	347-225-140
160 mm – 6 ¼ "	347-223-160
180 mm – 7 "	347-223-180

Katheterzangen
Catheter forceps

Pinces pour cathéters
Pinzas para catéteres
Pinze per catetere



MAGILL

160 mm – 6¼"	16-741-160		
200 mm – 8"		16-741-200	
250 mm – 9"			16-743-245

Laryngoskope
Laryngoscopes
Laryngoscopes
Laringoscopios
Laringoscopi

MCINTOSH

Fig. 0	Fig. 1	Fig. 2	Fig. 3	Fig. 4	Fig. 5
a = 56 mm	a = 68 mm	a = 88 mm	a = 108 mm	a = 128 mm	a = 150 mm
51-121-000	51-121-001	51-121-002	51-121-003	51-121-004	51-121-005

rostfrei
 stainless steel
 inoxydable
 inoxidable
 inossidabile



Fig. 0	Fig. 1	Fig. 2	Fig. 3	Fig. 4	Fig. 5
51-192-001	51-192-001	51-192-002	51-192-002	51-192-002	51-192-002

Ersatzlampe
 Spare lamp
 Lampe de rechange
 Bombilla de sustitución
 Lampadina di ricambio



	Fig. 0	Fig. 1	Fig. 2	Fig. 3	Fig. 4
	a = 55 mm	a = 70 mm	a = 90 mm	a = 110 mm	a = 130 mm
51-126-000			x	x	x
51-126-000/6		x	x	x	x
51-126-000/2	x	x	x	x	

Satz im Etui mit Griff rostfrei (Griff: 51-180-000, Seite 550)

Set in case with handle stainless steel (handle: 51-180-000, page 550)
 Trousse à laryngoscopie en boîte avec manche inoxydable (manche: 51-180-000, page 550)
 Juego de laringoscopia, en caja, con mango inoxidable (mango: 51-180-000, página 550)
 Astuccio da laringoscopia, in cassetta, manico inossidabile (manico: 51-180-000, pagina 550)

	51-120-006	51-120-002	51-120-000
--	------------	------------	------------

Etui für McIntosh, leer
 Case for McIntosh, empty
 Etui pour McIntosh, vide
 Estuche para McIntosh, vacío
 Astuccio per McIntosh, vuoto

für 3 Spatel
 for 3 blades
 pour 3 spatules
 para 3 espátulas
 per 3 spatole

für 4 Spatel
 for 4 blades
 pour 4 spatules
 para 4 espátulas
 per 4 spatole

für 5 Spatel
 for 5 blades
 pour 5 spatules
 para 5 espátulas
 per 5 spatole

Laryngoskope
Laryngoscopes
Laryngoscopes
Laringoscopios
Laringoscopi

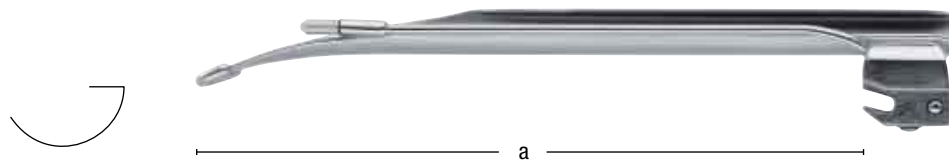

MILLER

Fig. 0	Fig. 1	Fig. 2	Fig. 3	Fig. 4
a = 55 mm	a = 80 mm	a = 130 mm	a = 170 mm	a = 180 mm
51-152-000	51-152-001	51-152-002	51-152-003	51-152-004

rostfrei
 stainless steel
 inoxydable
 inoxidable
 inossidabile



Fig. 0	Fig. 1	Fig. 2	Fig. 3	Fig. 4
51-192-001	51-192-001	51-192-002	51-192-002	51-192-002

Ersatzlampe
 Spare lamp
 Lampe de rechange
 Bombilla de sustitución
 Lampadina di ricambio

	Fig. 0	Fig. 1	Fig. 2	Fig. 3	Fig. 4
	a = 55 mm	a = 80 mm	a = 130 mm	a = 170 mm	a = 180 mm
51-153-000			x	x	x
51-153-004		x	x	x	x
51-153-008	x	x	x	x	x

Satz im Etui mit Griff rostfrei (Griff: 51-180-000, Seite 550)
 Set in case with handle stainless steel (handle: 51-180-000, page 550)
 Trousse à laryngoscopie en boîte avec manche inoxydable (manche: 51-180-000, page 550)
 Juego de laringoscopia, en caja, con mango inoxidable (mango: 51-180-000, página 550)
 Astuccio da laringoscopia, in cassetta, manico inossidabile (manico: 51-180-000, pagina 550)

	51-118-000
--	------------

Etui für Miller, leer
 Case for Miller, empty
 Etui pour Miller, vide
 Estuche para Miller, vacío
 Astuccio per Miller, vuoto

für 5 Spatel
 for 5 blades
 pour 5 spatules
 para 5 espátulas
 per 5 spatole

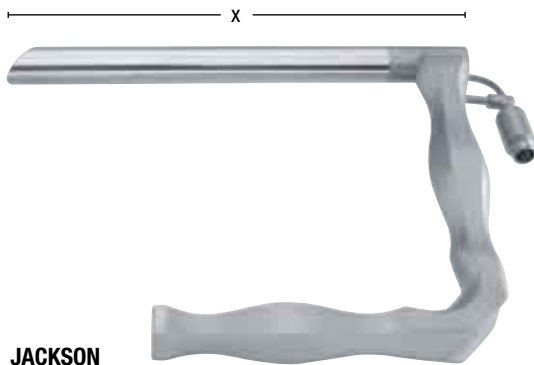
Laryngoskope
Laryngoscopes
Laryngoscopes
Laringoscopios
Laringoscopi

JACKSON

	x = 120 mm	x = 170 mm	x = 180 mm
	51-223-120	51-223-170	51-223-180
Jackson mit Lichtträger, rostfrei Jackson with light carrier, stainless steel Jackson avec porte de lumière, inoxydable Jackson con porta fibras, inoxidable Jackson con porta luce, inossidabile	für Säuglinge for babies pour nourissons para lactantes per lattanti	für Kinder for children pour enfants para niños per bambini	für Erwachsene for adults pour adultes para adultos per adulti

	x = 120 mm	x = 170 mm	x = 180 mm
	51-250-120	51-250-170	51-250-180
Lichtträger, allein, für Jackson Light carrier, only, for Jackson Porte de lumière, seul, pour Jackson Porta fibras, sola, para Jackson Porta luce, sola, per Jackson	für Säuglinge for babies pour nourissons para lactantes per lattanti	für Kinder for children pour enfants para niños per bambini	für Erwachsene for adults pour adultes para adultos per adulti

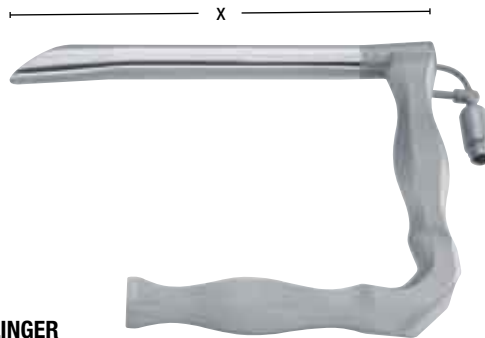
Laryngoskope
Laryngoscopes
Laryngoscopes
Laringoscopios
Laringoscopi



HOLINGER

	x = 171 mm	x = 180 mm
	51-217-171	51-217-180

Holinger mit Lichtträger, rostfrei
 Holinger with light carrier, stainless steel
 Holinger avec porte de lumière, inoxydable
 Holinger con porta fibras, inoxidable
 Holinger con porta luce, inossidabile

	x = 171 mm	x = 180 mm
	51-218-171	51-218-180

Lichtträger, allein, für Holinger
 Light carrier, only, for Holinger
 Porte de lumière, seul, pour Holinger
 Porta fibras, sola, para Holinger
 Porta luce, solo, per Holinger

Laryngoskop-Griffe

Laryngoscope handles

Manches pour laryngoscopes

Mangos de laringoscopios

Manici per laringoscopi



51-178-000

rostfrei
stainless steel
inoxydable
inoxidable
inossidabile



51-180-000

rostfrei
stainless steel
inoxydable
inoxidable
inossidabile



Alle Griffe sind nur in Gas sterilisierbar oder in einer Lösung zu desinfizieren. Keine Sterilisation in Autoklaven und Heissluft. In jedem Fall vorher den Akkumulator oder den Batteriecontainer entnehmen.

All handles are only sterilizable in a gassterilizer or can be cleaned in a disinfection solution. Not autoclavable and no sterilisation in hot-air. Akkumulator or battery housing must be taken off before.

Toutes les manches peuvent être stérilisées à gaz ou dans une solution désinfectante. Aucune stérilisation dans l'autoclave et à l'air chaud. Accumulateur ou contenair des piles doit être enlevé.

Todos los mangos son solamente esterilizables en gas o en una solución de desinfección. No esterilizar en el autoclave o con aire caliente. En todo caso, quitar el acumulador o el contenedor de las pilas.

Tutti i manici sono soltanto immergibili oppure sterilizzabili in gas. Nessuna sterilizzazione in autoclave o aria calda. In tutti i casi dovette prima rimuovere l'accumulatore o il contenitore di batterie.

Laryngoskope – Kaltlicht
Laryngoscopes – Cold light

Laryngoscopes – lumière froide
Laringoscopios – luz fría
Laringoscopi – luce fredda



MCINTOSH

Fig. 0	Fig. 1	Fig. 2	Fig. 3	Fig. 4	Fig. 5
a = 55 mm	a = 70 mm	a = 90 mm	a = 110 mm	a = 130 mm	a = 150 mm
51-126-000	521-126-001	51-126-002	51-126-003	51-126-004	51-126-005

rostfrei
 stainless steel
 inoxydable
 inoxidable
 inossidabile



	Fig. 0	Fig. 1	Fig. 2	Fig. 3	Fig. 4
	a = 55 mm	a = 70 mm	a = 90 mm	a = 110 mm	a = 130 mm
51-131-000			x	x	x
51-131-000/3		x	x	x	x
51-131-000/8	x	x	x	x	x

Satz im Etui mit Griff rostfrei (Griff: 51-174-000, Seite 553)
 Set in case with handle stainless steel (handle: 51-174-000, page 553)
 Trousse à laryngoscopie en boîte avec manche inoxydable (manche: 51-174-000, page 553)
 Juego de laringoscopia, en caja, con mango inoxidable (mango: 51-174-000, pagina 553)
 Astuccio da laringoscopia, in cassetta, manico inossidabile (manico: 51-174-000, pagina 553)



Sterilisier-Information: Alle Spatel können bis 134 °C im Autoklaven sterilisiert werden.
 Sterilizing information: All blades are autoclavable up to 134 °C.
 Information pour la stérilisation: Toutes les spatules peuvent être stérilisées jusqu'à 134 °C dans l'autoclave.
 Información para la esterilización: Todas las espátulas pueden ser esterilizadas en el autoclave a 134 °C.
 Informazione per la sterilizzazione: Tutte le spatole possono essere sterilizzate nell'autoclave fino a 134 °C.

Laryngoskope – Kaltlicht
Laryngoscopes – Cold light
Laryngoscopes – lumière froide
Laringoscopios – luz fría
Laringoscopi – luce fredda

MILLER

Fig. 0	Fig. 1	Fig. 2	Fig. 3	Fig. 4
a = 55 mm	a = 80 mm	a = 130 mm	a = 170 mm	a = 180 mm
51-154-000	51-154-001	51-154-002	51-154-003	51-154-004

rostfrei
 stainless steel
 inoxydable
 inoxidable
 inossidabile

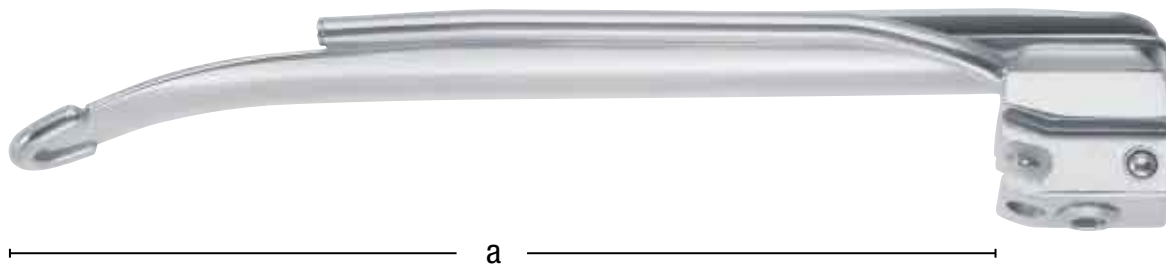

	Fig. 0	Fig. 1	Fig. 2	Fig. 3	Fig. 4
	a = 55 mm	a = 80 mm	a = 130 mm	a = 170 mm	a = 180 mm
51-151-000			x	x	x
51-151-001		x	x	x	x
51-151-002	x	x	x	x	x

Satz im Etui mit Griff rostfrei (Griff: 51-174-000, Seite 553)

Set in case with handle stainless steel (handle: 51-174-000, page 553)

Trousse à laryngoscopie en boîte avec manche inoxydable (manche: 51-174-000, page 553)

Juego de laringoscopia, en caja, con mango inoxidable (mango: 51-174-000, página 553)

Astuccio da laringoscopia, in cassetta, manico inossidabile (manico: 51-174-000, pagina 553)

Sterilisier-Information: Alle Spatel können bis 134 °C im Autoklaven sterilisiert werden.

Sterilizing information: All blades are autoclavable up to 134 °C.

Information pour la stérilisation: Toutes les spatules peuvent être stérilisées jusqu'à 134 °C dans l'autoclave.

Información para la esterilización: Todas las espátulas pueden ser esterilizadas en el autoclave a 134 °C.

Informazione per la sterilizzazione: Tutte le spatole possono essere sterilizzate nell'autoclave fino a 134 °C.

Laryngoskop-Griffe – Kaltlicht

Laryngoscope handles – Cold light

Manche pour laryngoscopes – lumière froide

Mangos de laringoscopios – luz fría

Manici per laringoscopi – luce fredda



51-174-000

Griff mit Batteriencontainer und Halogen-Lampe
Handle with battery container and halogen lamp
Manche avec conteneur à pile et lampe halogène
Mango con contenedor para pilas, luz halógena
Manico con contenitore per pila, lampada alogena



51-174-001

Griff mit Batteriecontainer und Xenon-Lampe
Handle with battery container and xenon lamp
Manche avec conteneur à pile et lampe xenon
Mango con contenedor para pilas, luz xenón
Manico con contenitore per pila, luce xenon

Akkumulatoren und Batteriecontainer

Accumulators and battery containers

Accumulateurs et conteneurs de piles

Acumuladores y contenedores para pilas

Accumulatori e contenitori per pila

1:1



2,5 V

51-175-002

für Batteriehandgriffe

for battery
pour de piles
para de pilas
per manici a pila

Xenon Ersatzlampen, 1 Packung à 6 Stück

Xenon spare lamps, pack of 6 pieces
Xenon lampe de rechange, jeu de 6 pièces
Xenón bombilla de cambio, juego de 6 piezas
Lampadina di ricambio Xenon, confezione da 6 pezzi

1:1



51-175-001

Halogen Ersatzlampe

Halogen spare lamp
Halogène lampe de rechange
Halógeno bombilla de cambio
Lampadina di ricambio alogena

Operationslaryngoskope Operation laryngoscopes

Laryngoscopes pour interventions chirurgicales
Laringoscopios para operaciones
Laringoscopi per l'intervento chirurgico



Fig. 1	
x = 135 mm	51-080-001

Rostfreier Edelstahl
Stainless steel
Acier inoxydable
Acero inoxidable
Acciaio inossidabile



Fig. 2	
x = 152 mm	51-080-002

Rostfreier Edelstahl
Stainless steel
Acier inoxydable
Acero inoxidable
Acciaio inossidabile

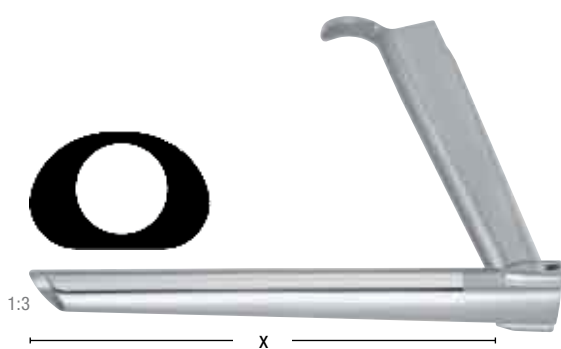

Fig. 3	
x = 182 mm	51-080-003

Rostfreier Edelstahl
Stainless steel
Acier inoxydable
Acero inoxidable
Acciaio inossidabile

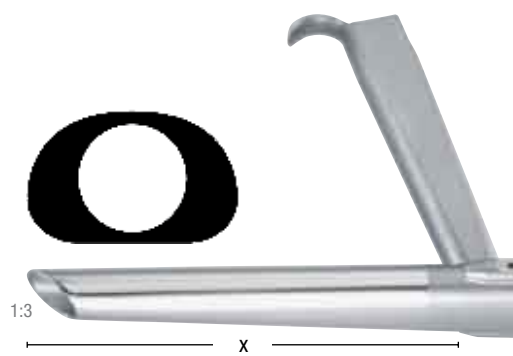
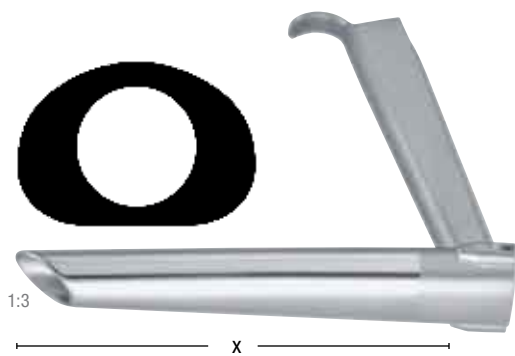

Fig. 4	
x = 172 mm	51-080-004

Rostfreier Edelstahl
Stainless steel
Acier inoxydable
Acero inoxidable
Acciaio inossidabile

Operationslaryngoskope
Operation laryngoscopes
Laryngoscopes pour interventions chirurgicales
Laringoscopios para operaciones
Laringoscopi per l'intervento chirurgico

Fig. 5

x = 172 mm

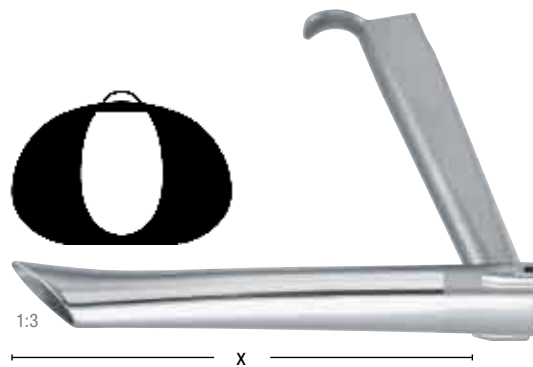
51-080-005

Rostfreier Edelstahl
 Stainless steel
 Acier inoxydable
 Acero inoxidable
 Acciaio inossidabile

Fig. 6

x = 182 mm

51-080-006

Rostfreier Edelstahl
 Stainless steel
 Acier inoxydable
 Acero inoxidable
 Acciaio inossidabile

Fig. 7

x = 222 mm

51-080-007

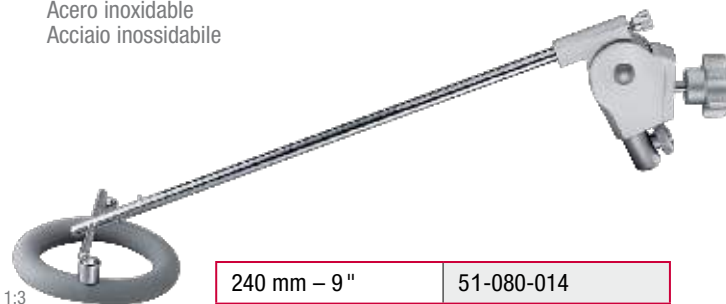
Rostfreier Edelstahl
 Stainless steel
 Acier inoxydable
 Acero inoxidable
 Acciaio inossidabile

240 mm – 9"

51-080-014

Bruststütze mit Stützstange für Erwachsene
 Chest-support with support-rod for adults
 Appui-poitaine avec tige pour adultes
 Soporte de pecho con vara para adultos
 Supporto per petto con asta per adulti

240 mm – 9"

51-080-012

Stützstange für Kinder
 Support-rod for children
 Tige pour enfants
 Vara para niños
 Asta per bambini

Fiberglas-Lichtträger
Fibreglass light-guides
Portes lumière-froide
Porta fibras
Porta luce fibreottica



51-080-020

für Laryngoskope 51-080-001 – 51-080-002
for laryngoscopes 51-50-01 – 51-50-02 pour
laryngoscopes 51-50-01 – 51-50-02 para
laringoscópios 51-50-01 – 51-50-02 per
laringoscopi 51-50-01 – 51-50-02



51-080-022

Rauchabsaugrohr für Laryngoskope 51-080-003 – 51-080-006
Suction tube for laryngoscopes 51-50-03 – 51-50-07
Tube d'aspiration pour laryngoscopes 51-50-03 – 51-50-07
Tubo de aspiración para laringoscópios 51-50-03 – 51-50-07
Tubo d'aspirazione per laringoscopi tk 51-50-03 – tk 51-50-07



51-080-030

Injektionskanüle für Laryngoskope 51-080-001 – 51-080-007
Injections drain tube for laryngoscopes 51-50-01 – 51-50-07
Canule à injection pour laryngoscopes 51-50-01 – 51-50-07
Cánula de inyección para laringoscópios 51-50-01 – 51-50-07
Cannula d'iniezione per laringoscopi 51-50-01 – 51-50-07



51-080-024

für Laryngoskop 51-080-007
for laryngoscope 51-50-07
pour laryngoscope 51-50-07
para laringoscópio 51-50-07
per laringoscopia 51-50-07